

QLUV04X3U-XXX
3030 UV LED



Product Outline:

This is the high power LED with reflector type. EMC 3030 UV LED series are designed for high current operation and high power output applications. Quelighting UV LED is ideal UV light source for curing, printing, and detecting applications

Features:

- High Power UV LED
- Max. current = 700mA
- Package Dimension = 3.2mmX3.0mmX0.6mm
- View angel >120°
- RoHS compliant
- ESD 8KV
- Custom Bin available upon special request

Application:

- UV Curing
- Printing and Coating
- Adhesive
- Medical applications
- Industrial facility applications

Compliance and Certification:



Mechanical Property:

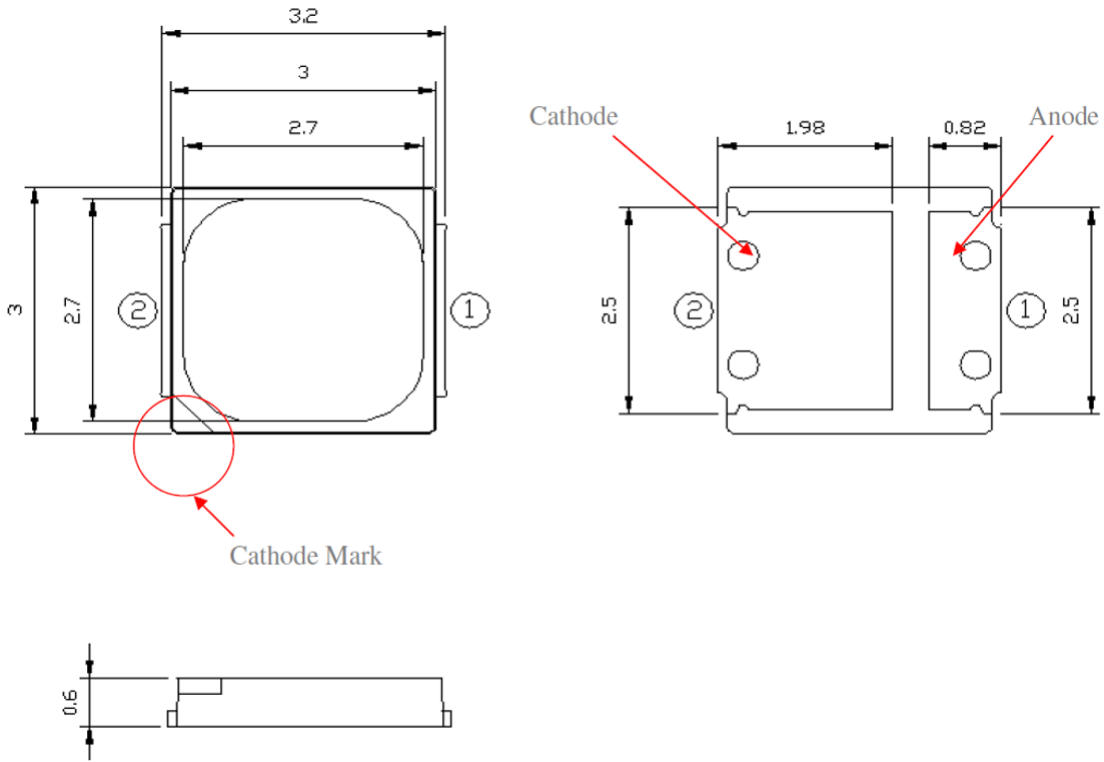

Note:

1. All dimension in millimeters
2. tolerance is $\pm 0.2\text{mm}$

Recommended Solder footprint:

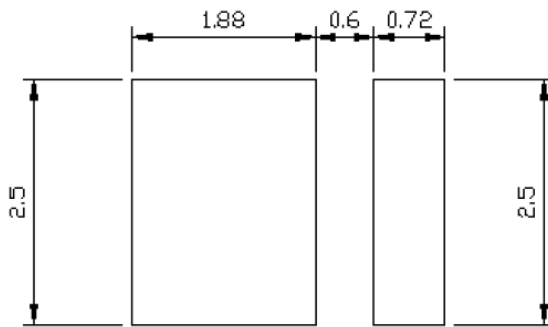

Note:

1. All dimension in millimeters
2. The drawing without tolerances is for reference only
3. Suggest stencil $T=0.1\text{ mm}$



Electrical / Optical Characteristic

(T=25 °C)

Product	View angle	I _F (mA)	V _F (V)		Wavelength (nm)	Radiant Power(mW)	
			Typ.	max		min	typ.
QLUV04M3U-365nm	>120	350	3.5	3.8	360-370		250
QLUV04L3U-385nm	>120	350	3.5	3.8	380-390		300
QLUV04K3U-395nm	>120	350	3.3	3.6	390-400		310
QLUV04J3U-405nm	>120	350	3.2	3.5	400-410		310
QLUV04H3U-420nm	>120	350	3.2	3.5	420-430		365

- (1) The Forward Voltage tolerance is $\pm 0.1V$
- (2) The Peak wavelength tolerance is ± 2
- (3) The Radiant power is $\pm 7\%$

Characteristics

■ Absolute Maximum Ratings

 (T_a=25°C)

Parameter	Symbol	Rating	Unit
DC Forward Current	I _f	700	mA
Leakage Current (5V)	I _r	10	μA
Power Dissipation	P _d	2.5	W
Pulse Forward Current	I _{fp}	700	mA
LED Junction Temperature	T _J	85	°C
Storage Temperature	T _{stg}	-40 ~ 80	°C
Operation Temperature	T _{opr}	-40 ~ 85	°C
Soldering Temperature	T _{sol}	260 < 10 sec	°C
Thermal Resistance Junction / Solder Point	R _{th}	Typ. 13.1	°C/W

*Duty 1/10 @ 10Khz

** Junction Temperature

*** IR Reflow for no more than 10 sec @ 260 °C

**** Thermal resistance is calculated from junction to solder



Peak Wavelength Binning

Wavelength Rank @ 350mA			
Code name	Low	High	Units
U360A	360	370	nm
U380A	380	390	
U390A	390	400	
U400A	400	410	
U420A	420	430	

Forward Voltage (V_F) Bin:

VF rank @ 350mA			
Code name	Low	High	Units
23	3	3.2	V
45	3.2	3.4	
67	3.4	3.6	
89	3.6	3.8	
A0	3.8	4.0	

The forward voltage tolerance is $\pm 0.2V$

Radiant Power Binning:

Radiant Power rank (mW) @ 350mA			
Code name	Low	High	Units
P02	200	300	mW
P03	300	400	
P04	400	500	
P05	500	600	

luminous flux tolerance is $\pm 7\%$



Characteristic Curves

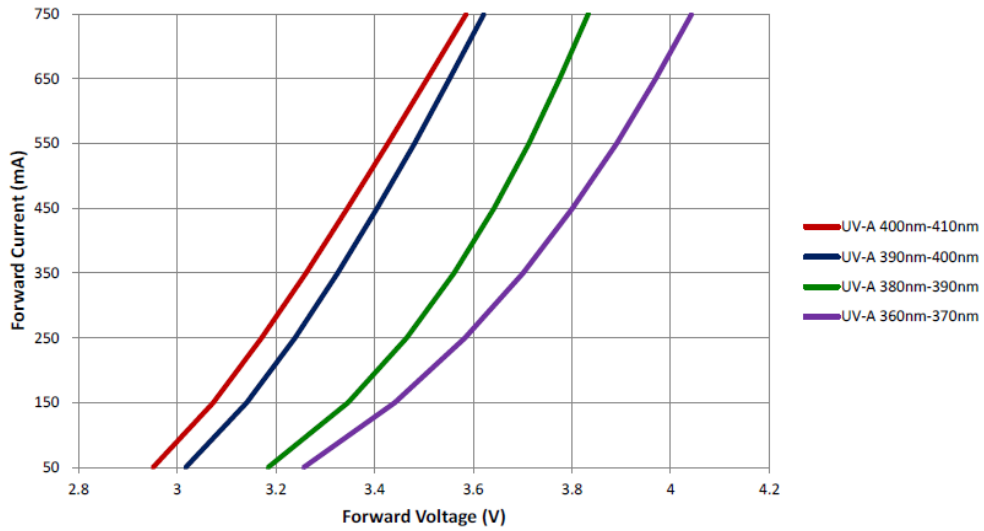

Forward Voltage vs. Forward Current

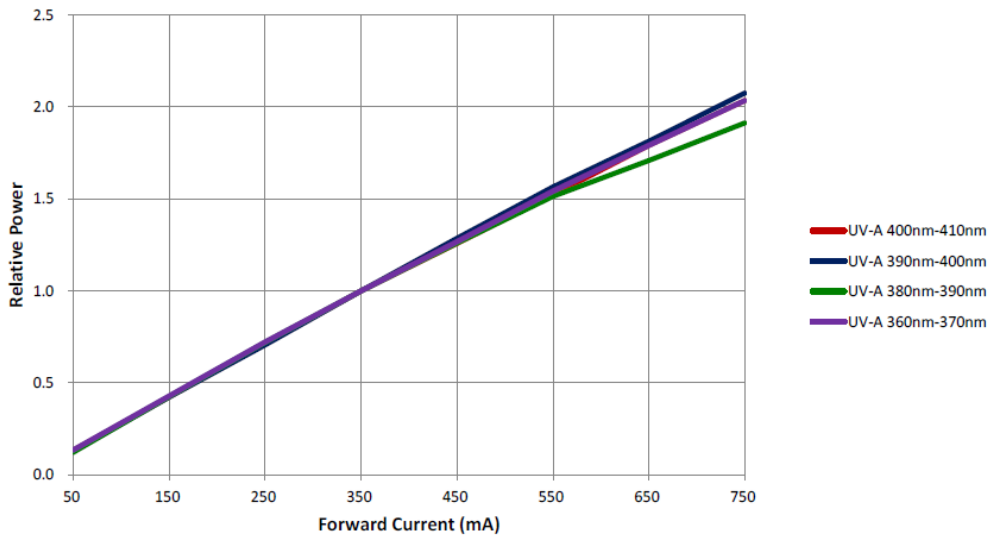

Forward current vs. Relative luminous intensity



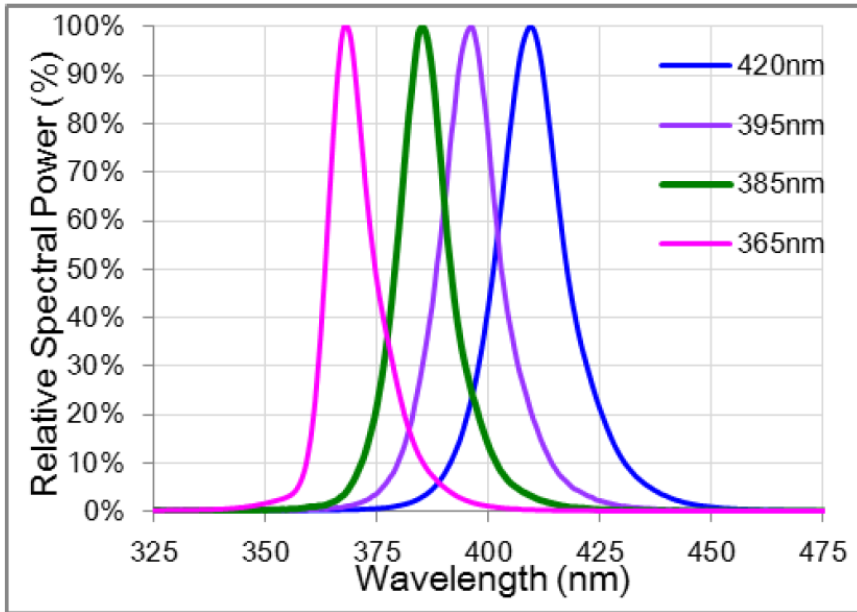

Spectrum Distribution

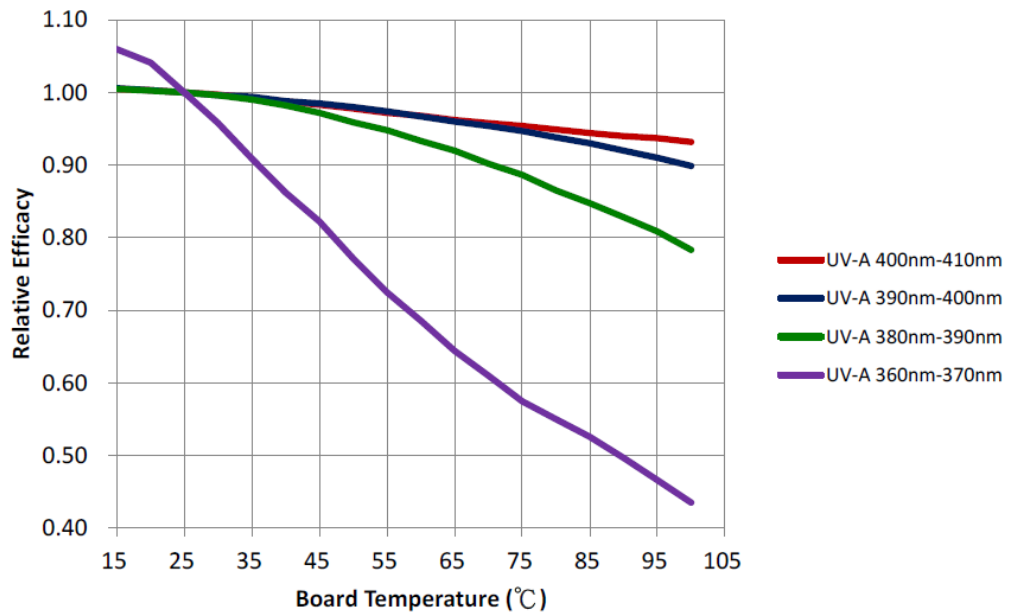

Relative Luminous Intensity vs Ambient Temperature



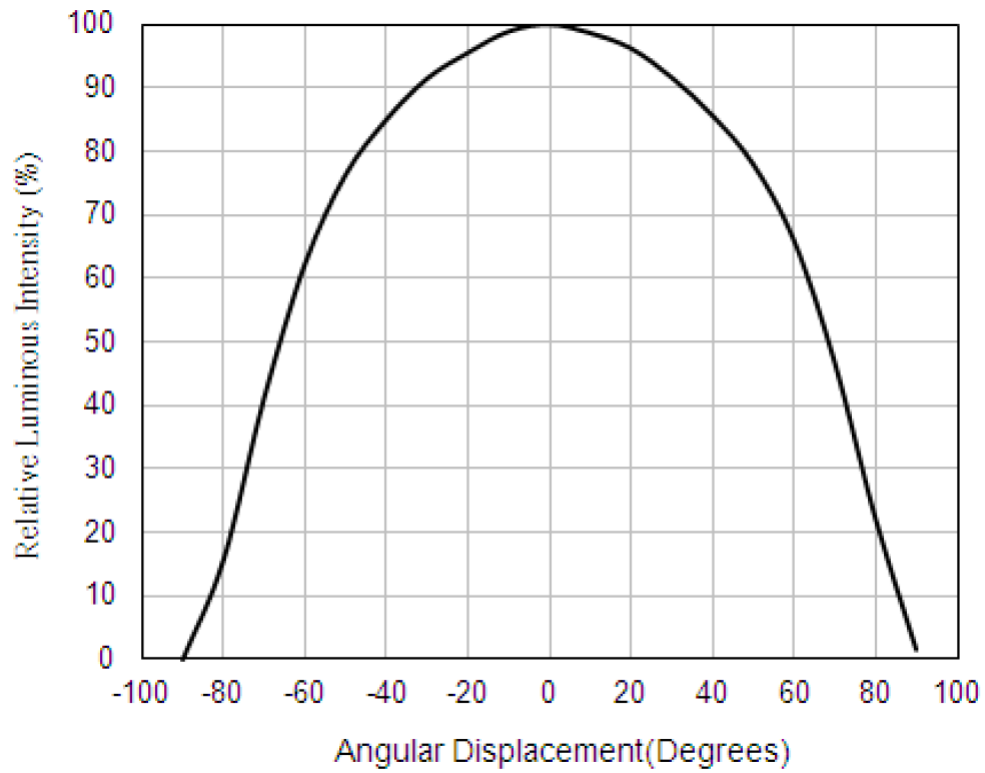

Typical Representative Spatial Radiation Pattern



■ Reliability test:

No	Item	Condition	Time/Cycle	Sample size
1	Steady State Operating Life of Room Temperature	25°C Operating	1000 Hrs	20 pcs
2	Steady State Operating Life of Low Temperature -40°C	-40°C Operating	1000 Hrs	20 pcs
3	Steady State Operating Life of Low Temperature 60°C	60°C Operating	1000 Hrs	20 pcs
4	Steady State Operating Life of Low Temperature 85°C	85°C Operating	1000 Hrs	20 pcs
5	Low temperature storage -40°C	-40°C Storage	1000 Hrs	20 pcs
6	High temperature storage 100°C	100°C Storage	1000 Hrs	20 pcs
7	Steady State Operating Life of High Humidity Heat 60°C/90%	60°C/90% Operating	1000 Hrs	20 pcs
8	Steady State Pulse Operating Life Condition	25°C 10Hz duty=1/10 Operating	200 Cycle	20 pcs
9	Resistance to soldering heat on PCB (JEDEC MSL3)	pre-store @60°C, 60%RH for 52hrs Tslid max.=260 10sec	3 Times	20 pcs
10	Heat Cycle Test (JEDEC MRC)	25°C~65°C~-10°C, 90%RH, 24hr/1cycle	10 Cycle	20 pcs
11	Thermal shock	-40°C / 20min~ 5min~100°C /20min	300 Cycle	20 pcs

■ Judgment Criteria:

Item	Symbol	Test Condition	Judgment Criteria
Forward Voltage	Vf	350 mA	$\Delta Vf < 10\%$
Luminous Flux	Iv	350 mA	$\Delta Iv < 30\%$



Solder Profile:

-The recommended reflow soldering profile is as follows (temperatures indicated are as measured on the surface of the LED resin):

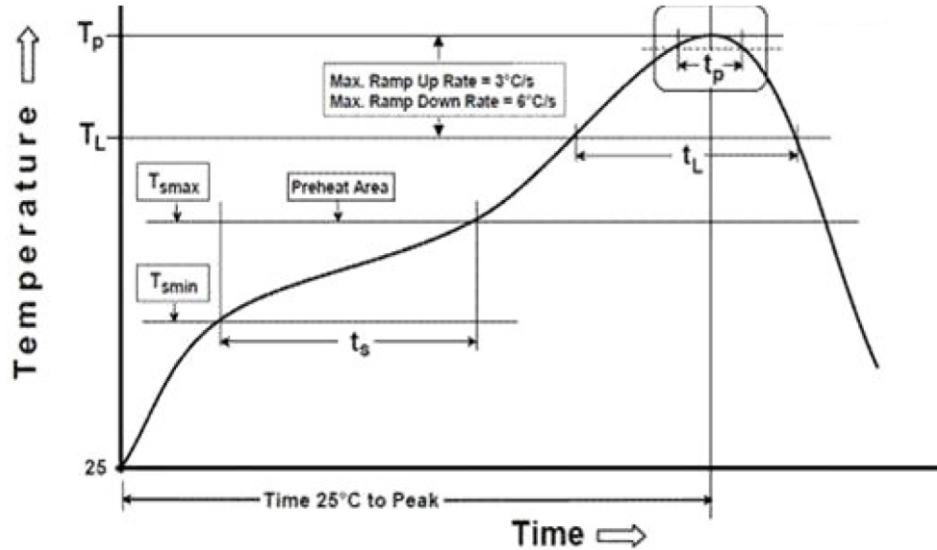

Profile Feature	Sn-Pb Eutectic Assembly	Pb-Free Assembly
Temperature Min(T_{smin})	100°C	150°C
Temperature Max(T_{smax})	150°C	200°C
Time(t_a) from (T_{smin} to T_{smax})	60-120 seconds	60-120 seconds
Ramp-up rate(T_L to T_p)	3°C/second max.	3°C/second max.
Liquidous Temperature(T_L)	183°C	217°C
Time(t_L) maintained above T_L	60-150 seconds	60-150 seconds
Peak package body temperature(T_p)	235°C	260°C
Time within 5°C of Actual Peak temperature (t_p)	20seconds*	30 seconds*
Ramp-down rate(T_p to T_L)	6°C/second max.	6°C/second max.
Time 25°C to peak temperature	6 minutes max.	8 minutes max.

* Tolerance for peak profile temperature (T_p) is defined as a supplier minimum and a user maximum.



Taping & Packing:

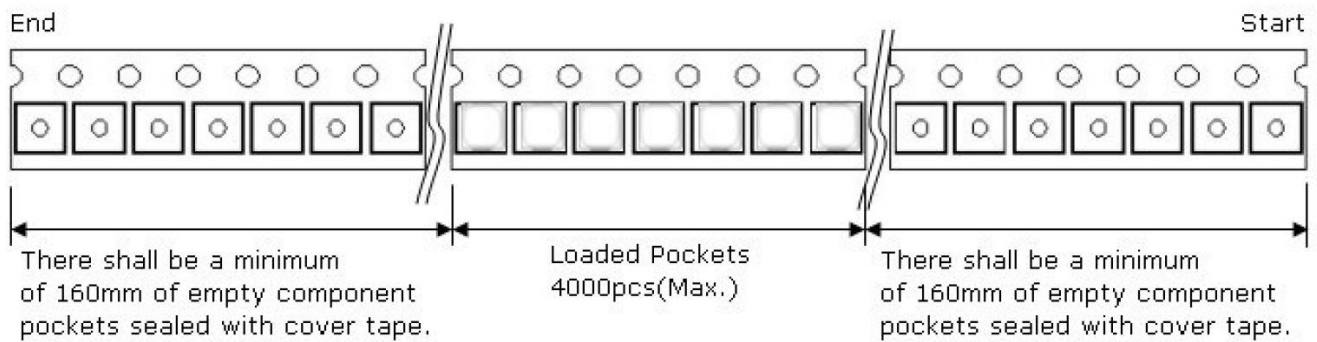
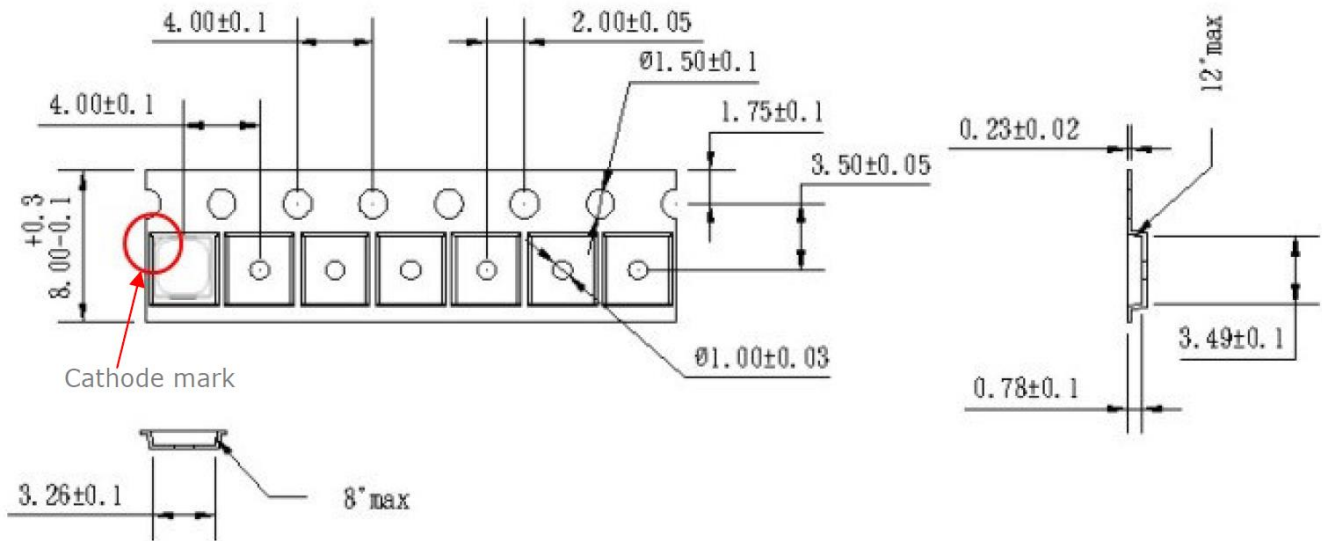

※ Drawing not to scale.

※ All dimensions are in millimeters.



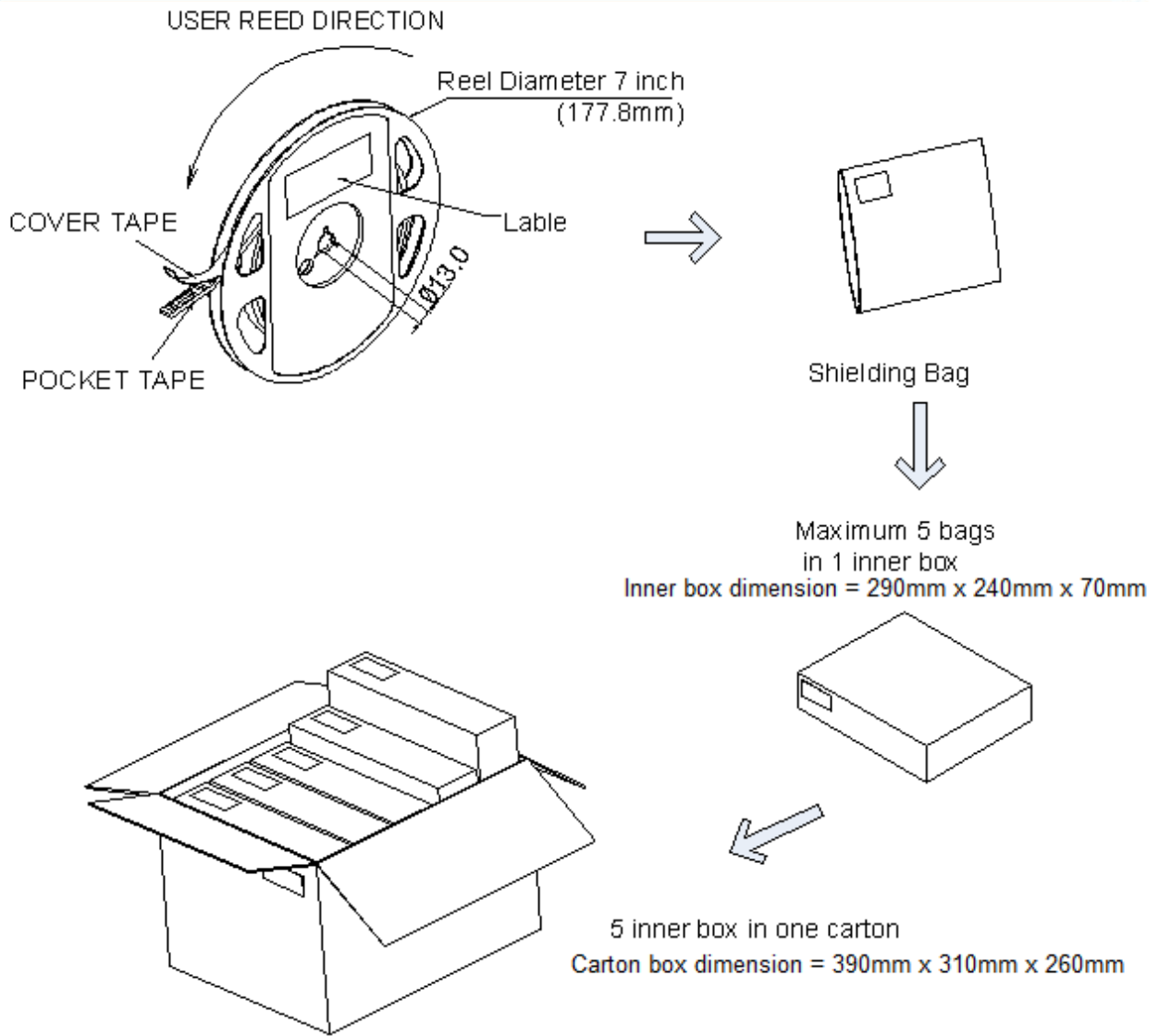

Labeling



Quantity: XXXX



Quelighting P/N: XXXXXX



Lot number: XXXXX



Iv Bin: XX

Color Bin: XX

Vf Bin: XX

Date Code: XXXX

Ordering Information:

Part #	Multiple Quantities	Quantity per Reel
QLUV04X3U-XXX		1000, 2000, 4000 pcs



Revision History:

Revision Date:	Changes:	Version #:
09-14-2018	Initial release	1.0
07-10-2021	Update the specification performance	1.1

