

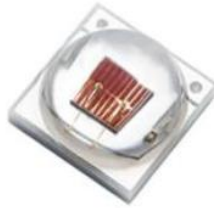

**Q** **QUELIGHTING**  
Sustainable Lighting Solution

---



**QLSP07XXU**  
( 3535 Color LEDs )



## Product Outline:

QLSP07XXU series are color LEDs bring high performance and quality of light to wide range of lighting application. The lighting application such as cation light, decoration light, signal, specific industrial and commercial lighting.

## Features:

- High brightness output @ 350mA,
- High driving current to 1000/1200mA
- Package Dimension = 3.5mmX3.5mmX2.2mm
- Low thermal resistance : <math><5^{\circ}\text{C}/\text{W}</math>
- ESD protection up to 4KV
- RoHS compliant
- Custom Bin available upon special request

## Application:

- Architecture Lighting
- Garden Lighting
- Warming lamp
- Indoor Lighting
- Outdoor Lighting

## Compliance and Certification:



## Mechanical Property:

### Blue / Royal Blue:

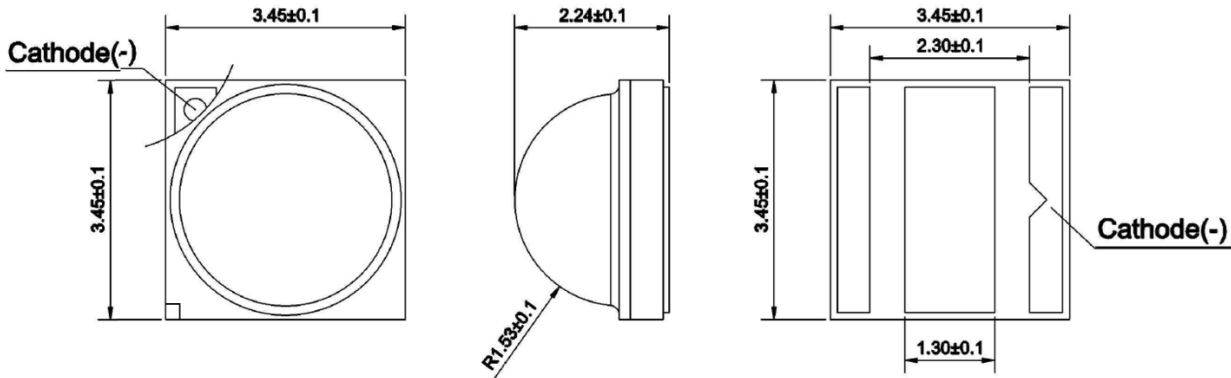

### Green, Cyan, Red, Amber, Crimson, Cherry Red:

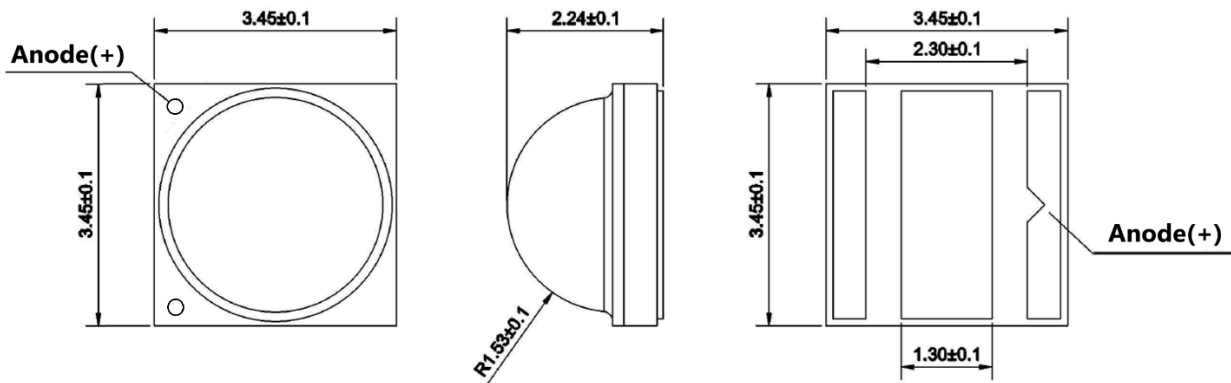

## Recommended Solder footprint:

### Recommended PCB solder pad:

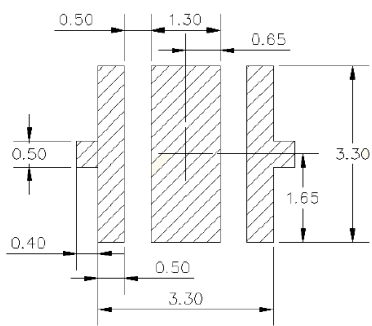

RECOMMENDED PCB SOLDER PAD

### Recommended stencil pattern:

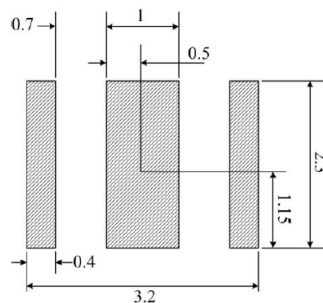

RECOMMENDED STENCIL PATTERN  
(HATCHED AREA IS OPENING)

- \* All dimensions are in millimeters.
- \* The LEDs is designed to be reflow soldered on to a PCB. IF dip soldered that QL cannot guarantee its reliability.
- \* Reflow soldering must not be performed more than twice.



## Electrical / Optical Characteristic

(T=25°C)

Product	Color	I <sub>F</sub> (mA)	V <sub>F</sub> (V)		Wavelength nm	Luminous Flux(lm)		Refer @ 700mA Typ.(lm)
			Typ.	max		min	typ.	
QLSP07RBU	Royal Blue	350	3.2	3.5	450~460	515mW	620mW	1100mW
QLSP07BU	Blue	350	3.2	3.5	460~475	40	50	71
QLSP07CGU	Cyan Green	350	3.2	3.5	495~515	70	80	138
QLSP07GU	Green	350	3.2	3.5	515~535	100	120	195
QLSP07AU	Amber	350	2.2	2.6	587~592	50	70	132
QLSP07RU	Red	350	2.2	2.6	615~630	60	70	119
QLSP07DRU	Deep Red	350	2.2	2.6	650~670	275mW	390mW	735mW
QLSP07CRU	Cherry Red	350	2.0	2.6	720~740	280mW	390mW	760mW

\*Tolerance = +/- 10%

## Absolute Maximum Rating

(T=25°C)

Part #	P <sub>d</sub> (mW)	I <sub>F</sub> (mA)	I <sub>FP</sub> (mA)*	V <sub>R</sub> (V)	T <sub>j</sub> (°C)	TOP (°C)	T <sub>ST</sub> (°C)	T <sub>SOL</sub> (°C)**	R <sub>th(J-S)</sub> (C/W)***
QLSP07RBU	4000	1200	1300	5	120	-40 – 85	-40 - 120	260	5
QLSP07BU	4000	1200	1300	5	120	-40 – 85	-40 - 120	260	5
QLSP07CGU	4000	1200	1300	5	120	-40 – 85	-40 - 120	260	5
QLSP07GU	4000	1200	1300	5	120	-40 – 85	-40 - 120	260	5
QLSP07AU	2000	1000	1300	5	120	-40 – 85	-40 - 120	260	5
QLSP07RU	2000	1000	1300	5	120	-40 – 85	-40 - 120	260	5
QLSP07DRU	2000	1000	1300	5	120	-40 – 85	-40 - 120	260	5
QLSP07CRU	2000	1000	1300	5	120	-40 – 85	-40 - 120	260	5

\*Duty 1/10 @ 10Khz

\*\* IR Reflow for no more than 10 sec @ 260 °C

\*\*\* Junction to substrate



**Dominate Wavelength (nm) Bin:**

Wd (nm)			
Color	Code name	Min.	Max.
Royal Blue	DA	450	455
	DB	455	460
Blue	DD	465	470
	DD	465	470
	DE	470	475
Cyan	DI5	495	505
	DK5	505	515
Green	DM	515	520
	DN	520	525
	DP	525	530
Amber	DS	585	590
	DT	590	595
Red	A7	615	620
	A8	620	625
	A9	625	630
Crimson	A145	650	660
	A165	660	670
Cherry Red	R730	720	740

Measurement tolerance is +/- 1nm

**Forward Voltage (VF) Bin:**

VF Rank (V)			
Color	Code name	Low	High
Royal Blue/ Blue/ Cyan/ Green	01	2.8	3.0
	23	3.0	3.2
	45	3.2	3.4
	67	3.4	3.6
Amber/ Red/ Crimson/ Cherry Red	NO	1.6	1.8
	PQ	1.8	2.0
	RS	2.0	2.2
	TU	2.2	2.4



	VW	2.4	2.6
--	----	-----	-----

The forward voltage tolerance is  $\pm 0.1V$

**Luminous Flux Bin:**

Rank @350mA (lm)			
Color	Code name	Low	High
Blue	QP9A	40	45
	QP9B	45	50
	QR9A	50	55
	QR9B	55	60
Cyan	QV9	80	90
	QW9	90	100
Green	QX9	100	110
	QY9	110	120
Amber	QR9	50	60
	QT9	60	70
	QU9	70	80
Red	QR9	50	60
	QT9	60	70
	QU9	70	80

luminous flux tolerance is  $\pm 7\%$

**Radiometric Power Bin:**

Rank @350mA (mW)			
Color	Code name	Low	High
Royal Blue	R	515	635
	S	635	755
Crimson	N	275	335
	P	335	435
	Q	435	515
Cherry Red	N	275	335
	P	335	435



## Characteristic Curves

### (1) Color Spectrum

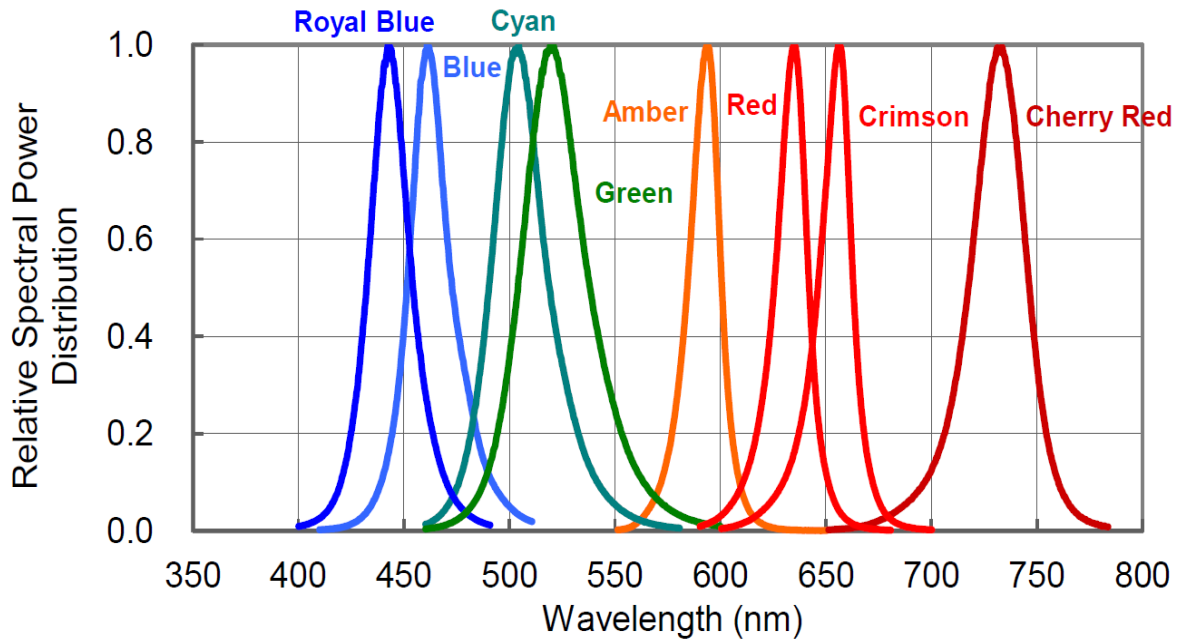

### (2). Typical Representative Spatial Radiation Pattern

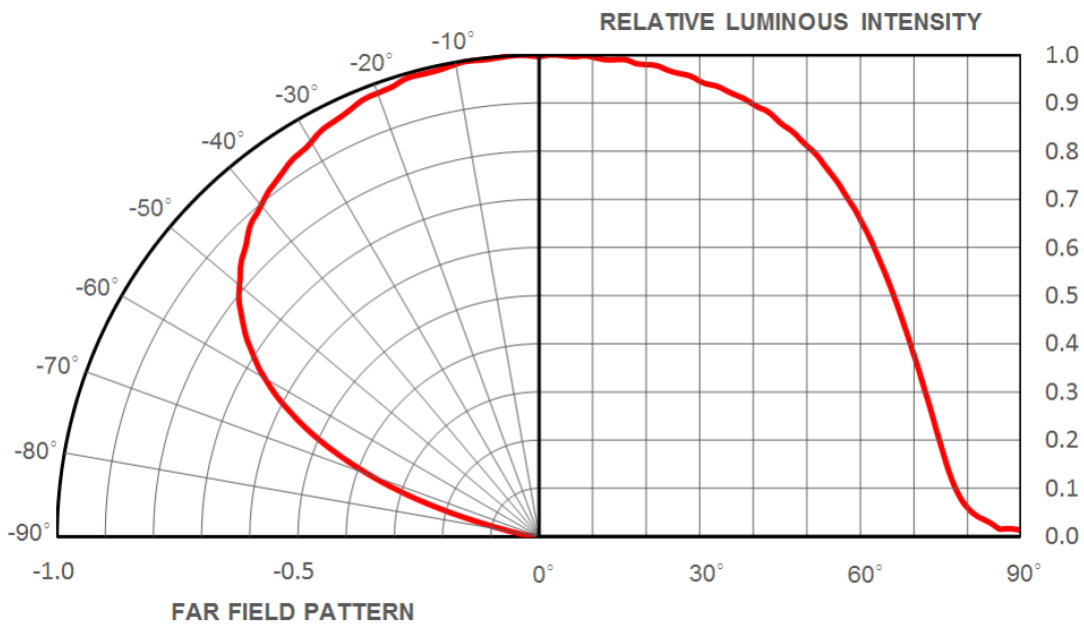

### (3). Forward Current Characteristics

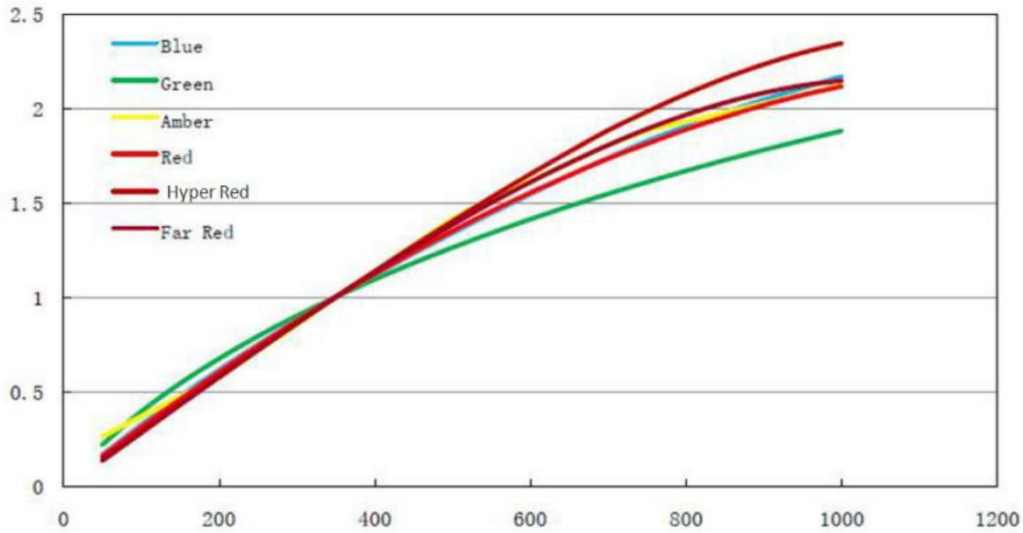

### (4). Forward Current vs Forward Voltage

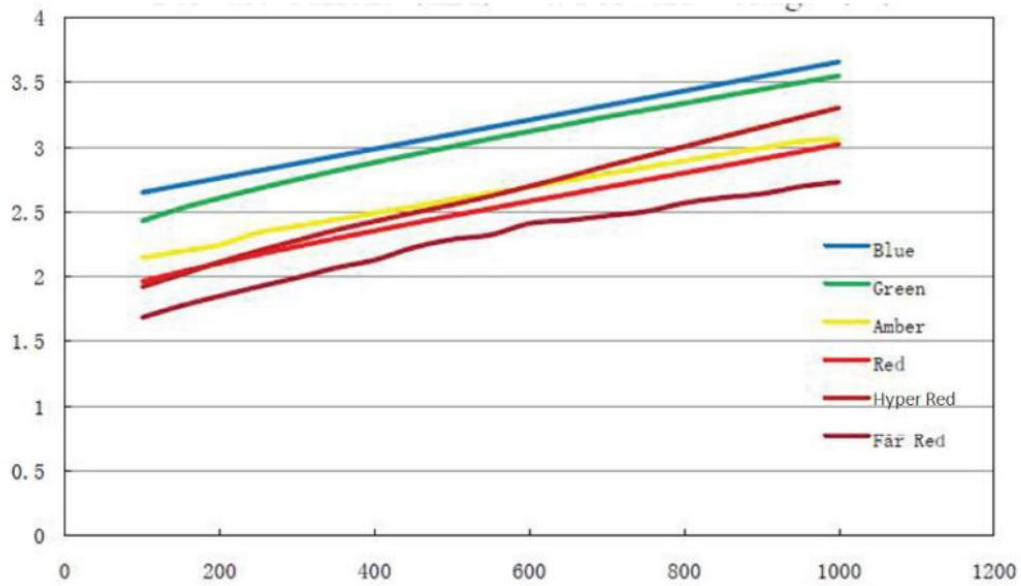



■ **Reliability test:**

No	Item	Condition	Time/Cycle	Sample size
1	Steady State Operating Life of Room Temperature	25°C Operating	1000 Hrs	20 pcs
2	Steady State Operating Life of Low Temperature -40°C	-40°C Operating	1000 Hrs	20 pcs
3	Steady State Operating Life of Low Temperature 60°C	60°C Operating	1000 Hrs	20 pcs
4	Steady State Operating Life of Low Temperature 85°C	85°C Operating	1000 Hrs	20 pcs
5	Low temperature storage -40°C	-40°C Storage	1000 Hrs	20 pcs
6	High temperature storage 100°C	100°C Storage	1000 Hrs	20 pcs
7	Steady State Operating Life of High Humidity Heat 60°C 90%	60°C/90% Operating	1000 Hrs	20 pcs
8	Steady State Pulse Operating Life Condition	25°C 10Hz duty=1/10 Operating	200 Cycle	20 pcs
9	Resistance to soldering heat on PCB (JEDEC MSL3)	pre-store@60°C, 60%RH for 52hrs Tslid max.=260 10sec	3 Times	20 pcs
10	Heat Cycle Test (JEDEC MRC)	25°C~65°C~-10°C, 90%RH, 24hr/1cycle	10 Cycle	20 pcs
11	Thermal shock	-40°C / 20min~ 5min~100°C /20min	300 Cycle	20 pcs

■ **Judgment Criteria:**

Item	Symbol	Test Condition	Judgment Criteria
Forward Voltage	Vf	350 mA	$\Delta Vf < 10\%$
Luminous Flux	Iv	350 mA	$\Delta Iv < 30\%$



## Solder Profile:

-The recommended reflow soldering profile is as follows (temperatures indicated are as measured on the surface of the LED resin):

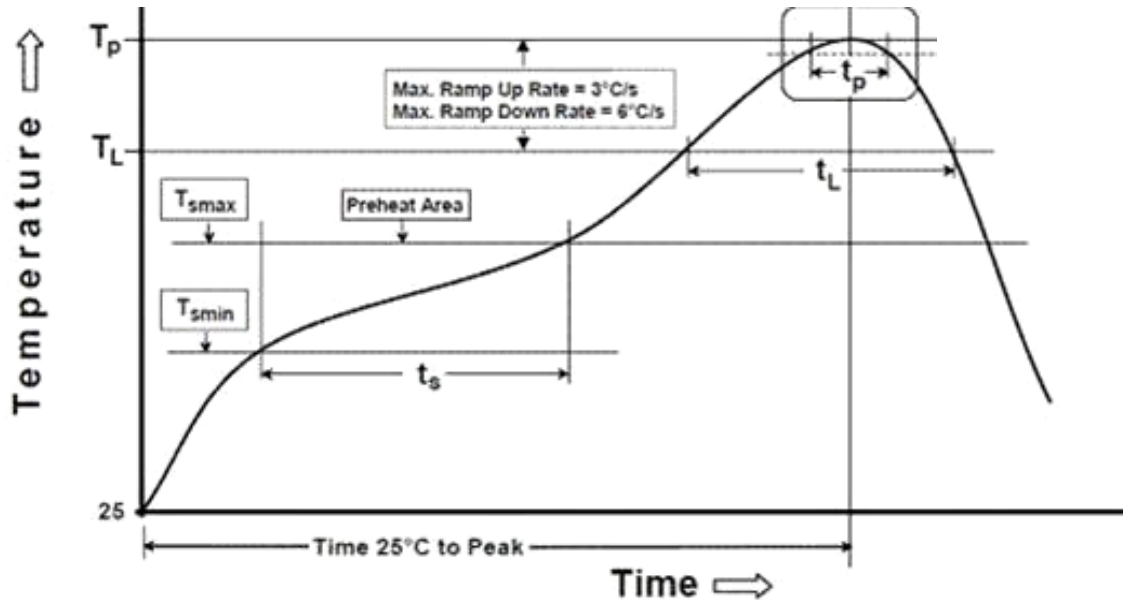

Profile Feature	Sn-Pb Eutectic Assembly	Pb-Free Assembly
Temperature Min( $T_{smin}$ )	100°C	150°C
Temperature Max( $T_{smax}$ )	150°C	200°C
Time( $t_a$ ) from ( $T_{smin}$ to $T_{smax}$ )	60-120 seconds	60-120 seconds
Ramp-up rate( $T_L$ to $T_P$ )	3°C/second max.	3°C/second max.
Liquidous Temperature( $T_L$ )	183°C	217°C
Time( $t_L$ ) maintained above $T_L$	60-150 seconds	60-150 seconds
Peak package body temperature( $T_P$ )	235°C	260°C
Time within 5°C of Actual Peak temperature ( $t_p$ )	20seconds*	30 seconds*
Ramp-down rate( $T_P$ to $T_L$ )	6°C/second max.	6°C/second max.
Time 25°C to peak temperature	6 minutes max.	8 minutes max.
* Tolerance for peak profile temperature ( $T_P$ ) is defined as a supplier minimum and a user maximum.		



## Taping & Packing:

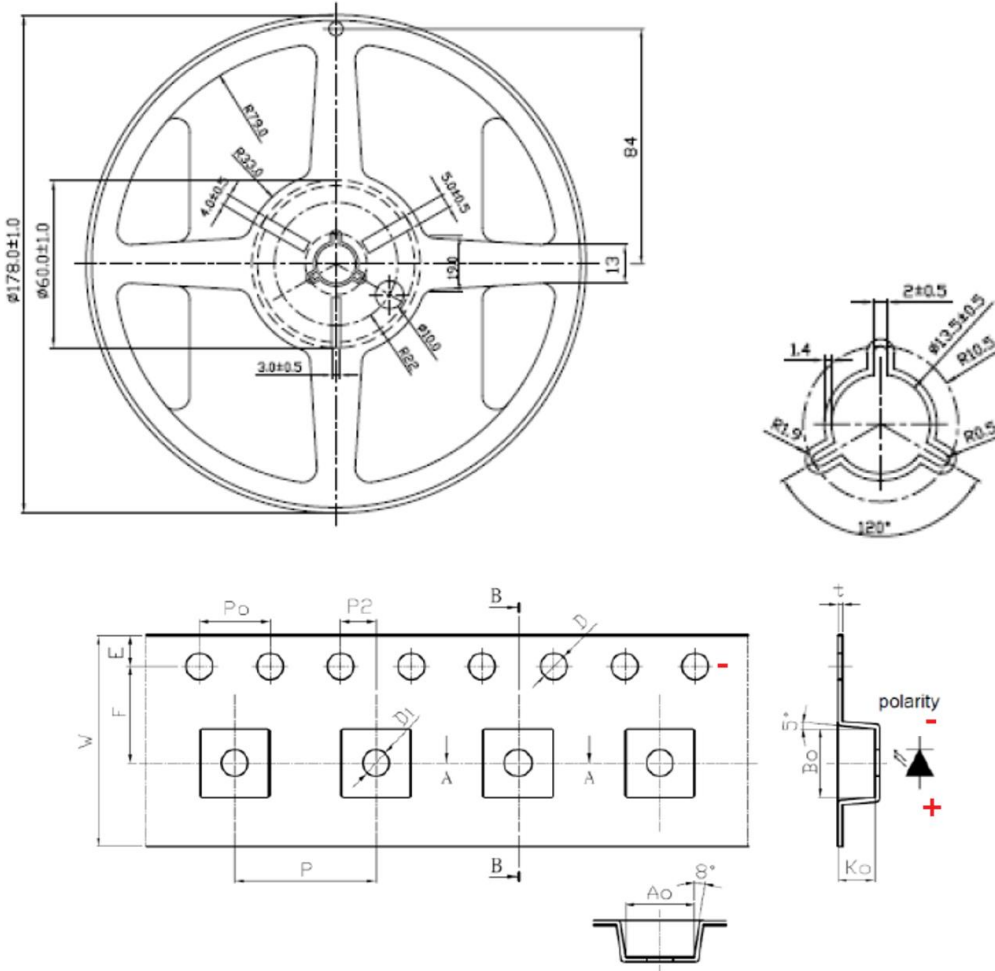

Notes: Dimensions are in millimeters.

Symbol	Dimension
W	12.00 +/- 0.10
P	8.00 +/- 0.10
E	1.75 +/- 0.10
F	5.50 +/- 0.05
P2	2.00 +/- 0.05
D	1.50+0.10 or 1.50-0.00
D1	1.50 +/- 0.10
Po	4.00 +/- 0.10
10Po	40.00 +/- 0.20
Ao	3.90 +/- 0.10
Bo	3.90 +/- 0.10
Ko	2.45 +/- 0.1
t	0.26 +/- 0.05

Unit : mm



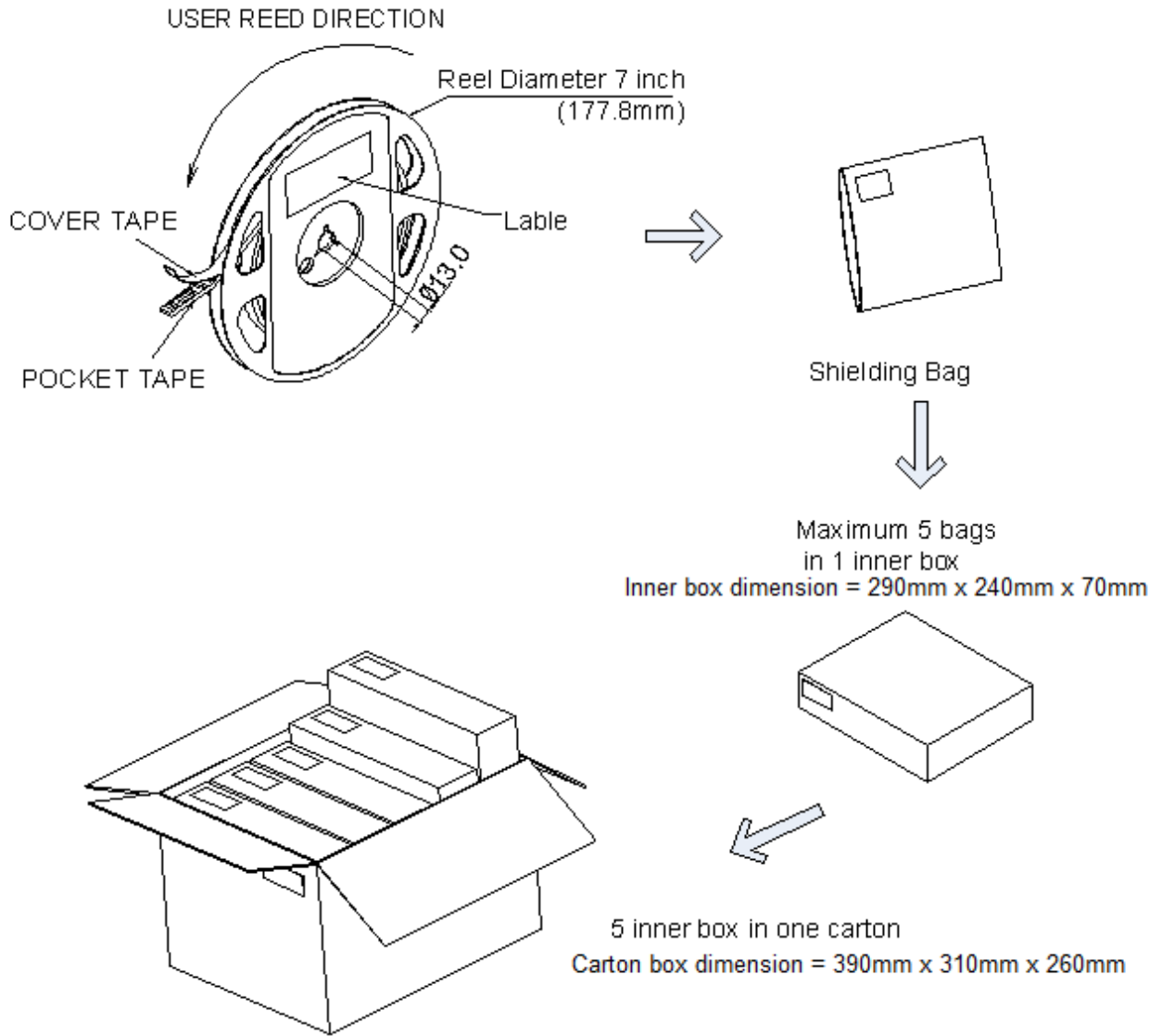

## Labeling

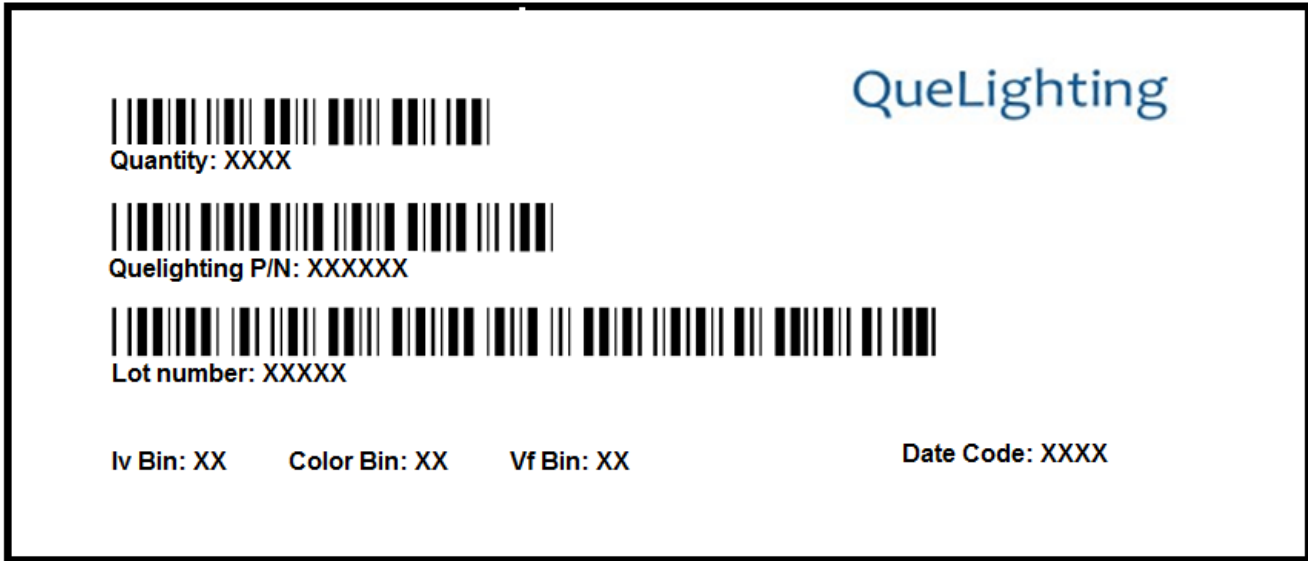

## Ordering Information:

Part #	Multiple Quantities	Quantity per Reel
QLSP07XXU		500,1000,2000 pcs



## Revision History:

Revision Date:	Changes:	Version #:
09-01-2017	Initial release	1.0
03-06-2019	Revise specification	1.1
08-07-2020	Update the specification	1.2
10-12-2021	Update the performance	2.0
6-19-2024	Upgrade the performance	2.1
11-18-2024	Upgrade the performance	2.2
11-25-2024	Updated the led outline drawing and polarity in packing reel	3.0

