

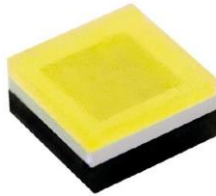

QUELIGHTING

Sustainable Lighting Solution



QLSP18UXWEU
(1616 Flat LED)



Product Outline:

QLSP18UXWEU series are high power Flat LEDs that bring high performance and quality of light to wide range of lighting application. The lighting application such as cation light, decoration light, signal, specific industrial and commercial lighting.

Features:

- White color
- RI, typ.**95**
- High brightness output @ 350mA,
- High driving current to 1000mA
- Package Dimension = 1.6mmX1.6mmX0.92mm
- Low thermal resistance : <math><6^{\circ}\text{C/W}</math>
- ESD protection up to 2KV
- RoHS compliant
- Custom Bin available upon special request

Application:

- Architecture Lighting
- Garden Lighting
- Exterior Automotive Lighting
- Warming lamp
- Indoor Lighting
- Outdoor Lighting

Compliance and Certification:



Mechanical Property: (Dimension)

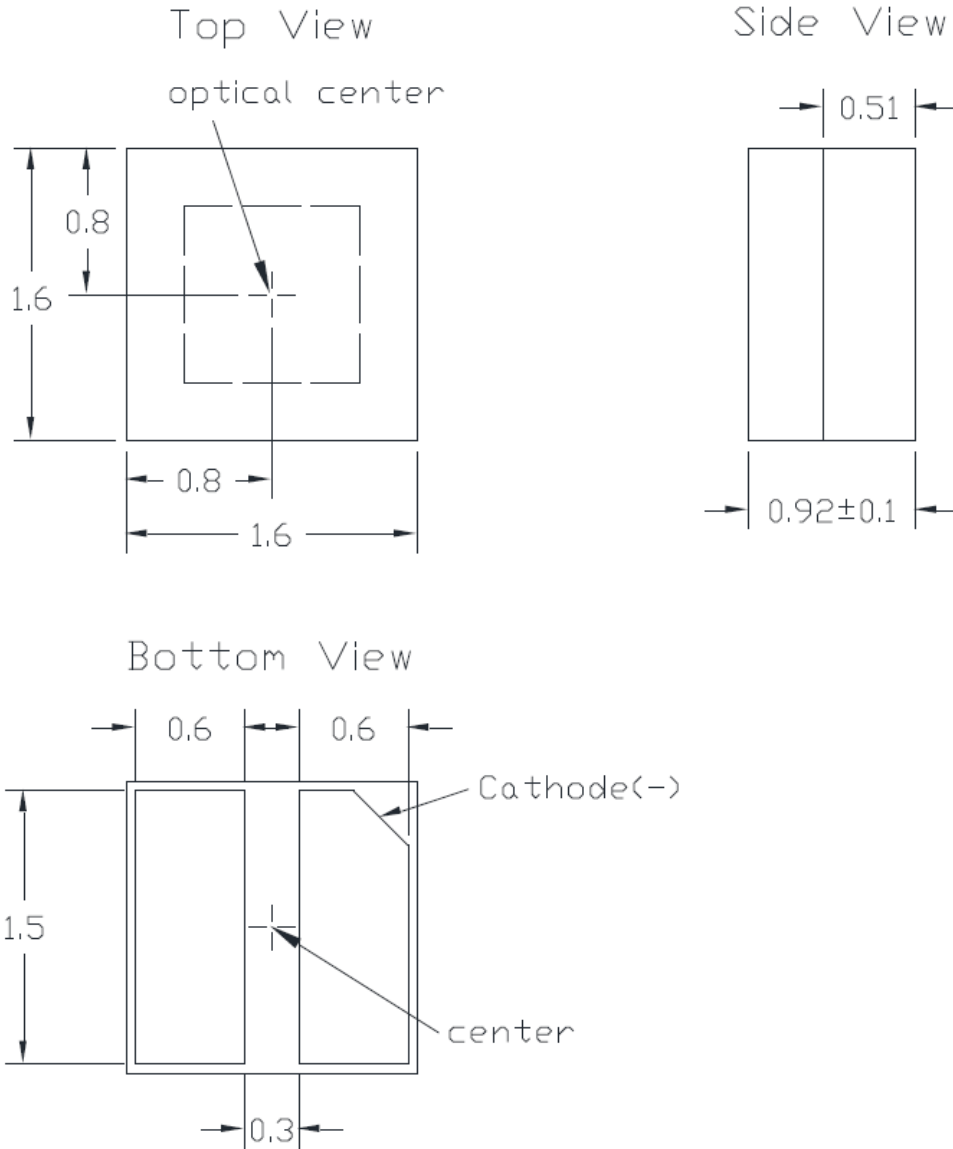

1. Unless otherwise indicated, tolerances are $\pm 0.10\text{mm}$.
2. Please do not solder the emitter by manual hand soldering, otherwise it will damage the emitter.
3. Please do not use a force of over **0.3kgf** impact or pressure on the lens of the LED, otherwise it will cause a catastrophic failure.



Recommended Solder footprint:

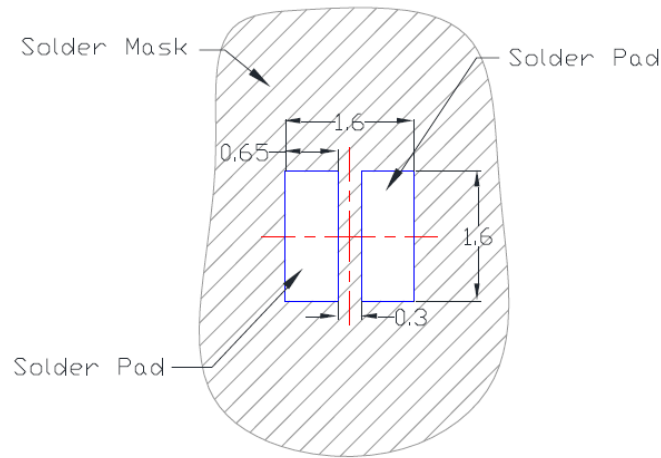

All dimensions are in millimeters.

Electrical / Optical Characteristic

(T=25 °C)

Product	Color	I _F (mA)	V _F (V)		Wavelength nm (CCT)	Luminous Flux(lm)		Refer @ 700mA Typ.(lm)
			Typ.	max		min	typ.	
QLSP18U1WEU	Warm White	350	3.0	3.4	2700K	80	90	160
QLSP18U2WEU	Warm White	350	3.0	3.4	3000K	80	95	170
QLSP18UNWEU	Neutral White	350	3.0	3.4	4000K	90	105	186
QLSP18UPWEU	Pure White	350	3.0	3.4	5000K	90	110	200
QLSP18UC1WEU	Cold White	350	3.0	3.4	5650K	90	110	200
QLSP18UC2WEU	Cold White	350	3.0	3.4	6500K	90	110	200

*Tolerance = +/- 7%

Absolute Maximum Rating

(T=25 °C)

Part #	P _d (mW)	I _F (mA)	I _{FP} (mA)*	V _R (V)	T _J (°C)	TOP (°C)	T _{ST} (°C)	T _{SOL} (°C)**	R _{th(J-S)} (C/W)***
QLSP18UXWEU	4000	1000	1300	5	125	-40~105	-40~120	260	6

*Duty 1/10 @ 10Khz

** IR Reflow for no more than 10 sec @ 260 °C

*** Junction to substrate



Chromaticity Coordinates

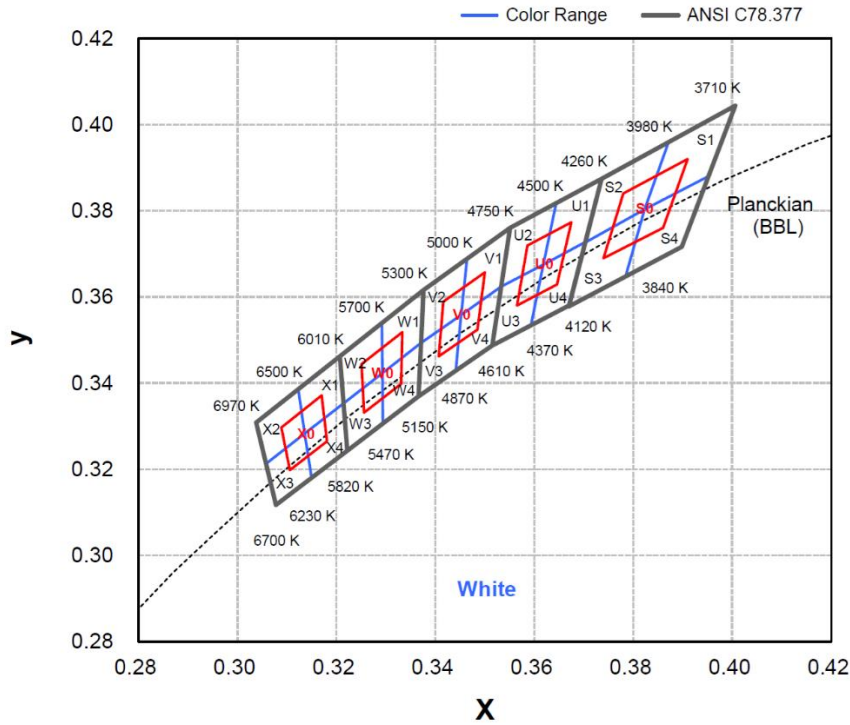

Chromaticity Coordinates (Warm White)

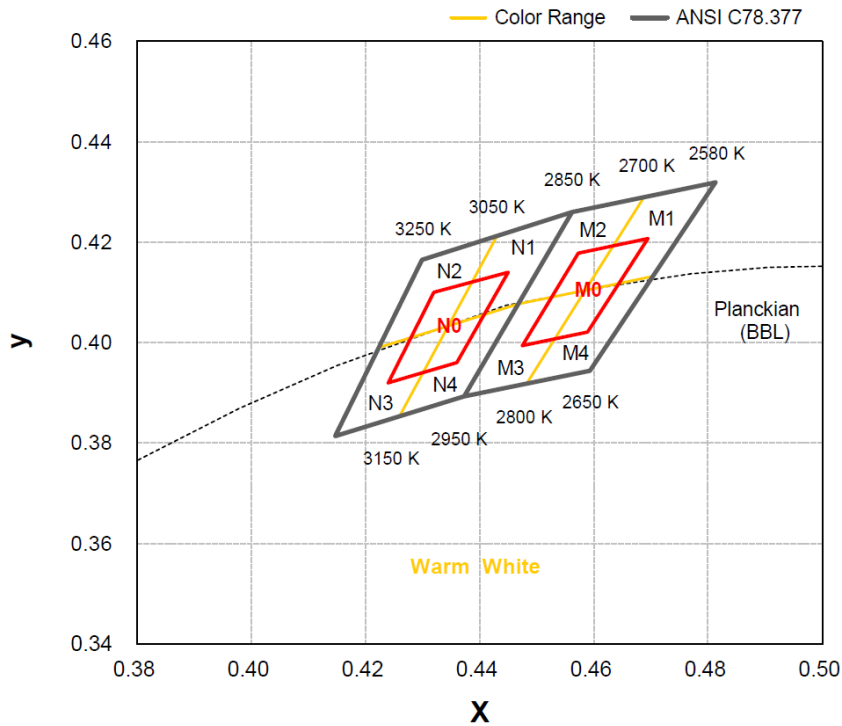

Note : 1. Correlated color temperature is derived from the CIE 1931 chromaticity diagram
2. CIE measurement tolerance is ± 0.007



Forward Voltage (VF) Bin:

VF Rank (V)			
Color	Code name	Low	High
White	A	2.8	3.0
	B	3.0	3.2
	D	3.2	3.4

Luminous Flux Bin:

Rank @350mA (lm)			
Color	Code name	Low	High
White	QV9	80	90
	QW9	90	100
	QX9	100	110
	QY9	110	120
	QZ9	130	140

luminous flux tolerance is $\pm 7\%$



Characteristic Curves

(1) Color Spectrum

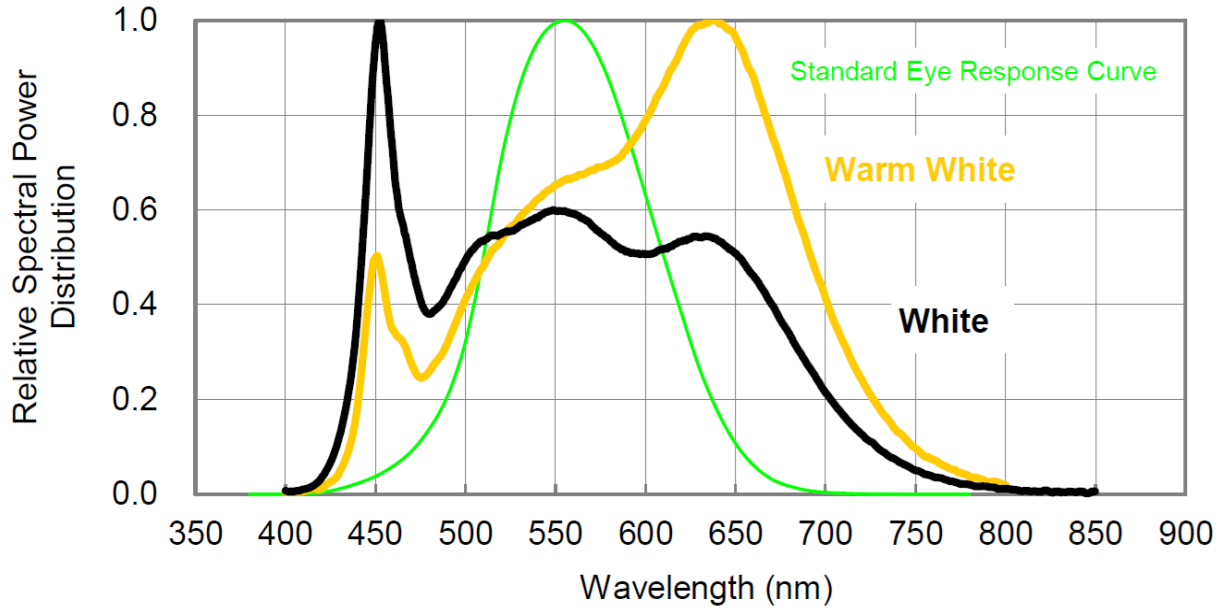

(2). Typical Representative Spatial Radiation Pattern

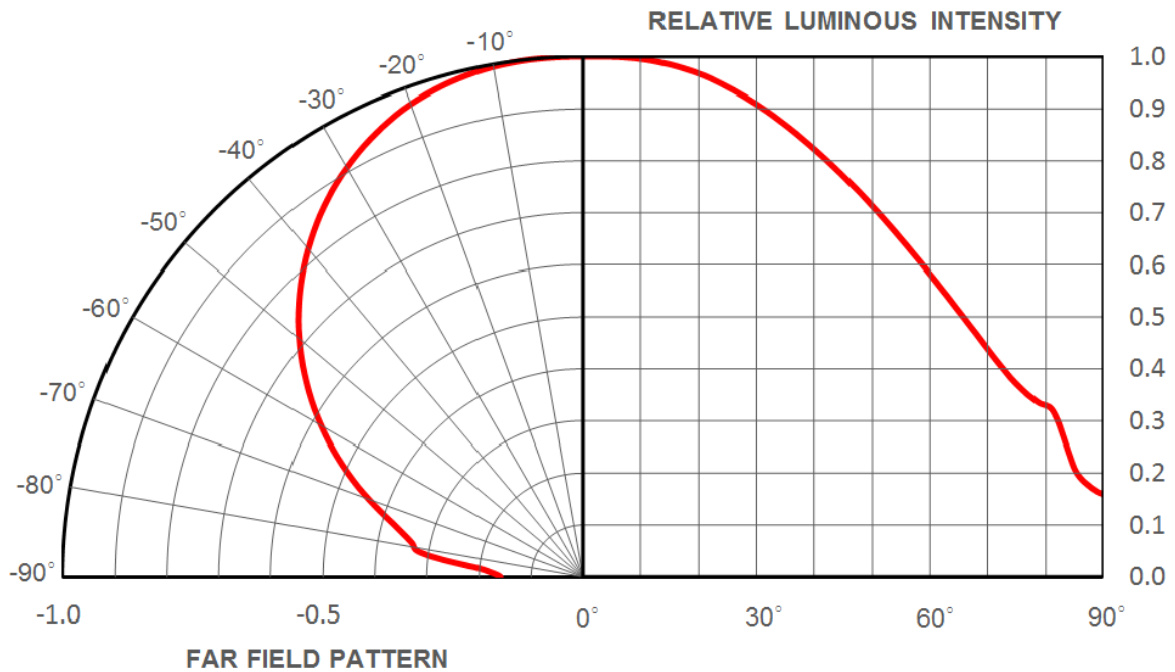

(3). Forward Current Characteristics

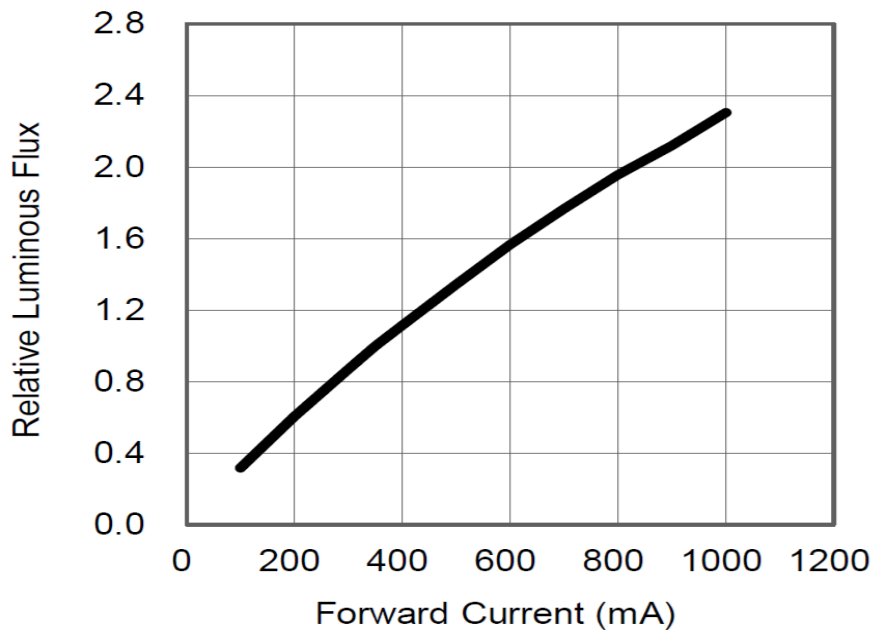

(4). Forward Current vs Forward Voltage

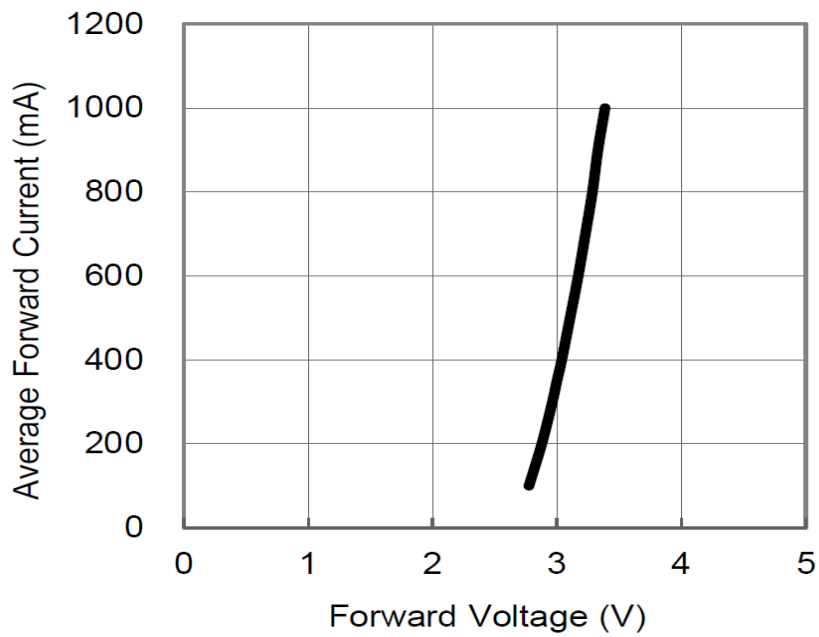

(5). Relative light output VS. T_j (IF = 350mA)

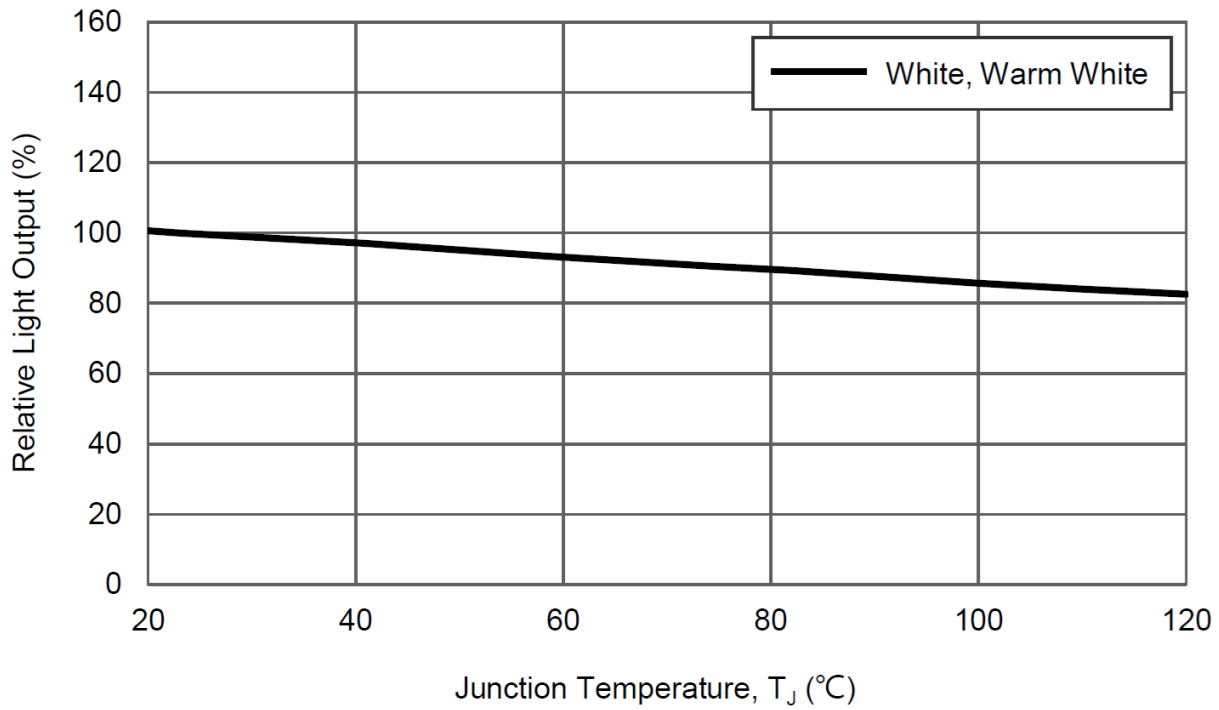

■ Reliability test:

No	Item	Condition	Time/Cycle	Sample size
1	Steady State Operating Life of Room Temperature	25°C Operating	1000 Hrs	20 pcs
2	Steady State Operating Life of Low Temperature -40°C	-40°C Operating	1000 Hrs	20 pcs
3	Steady State Operating Life of Low Temperature 60°C	60°C Operating	1000 Hrs	20 pcs
4	Steady State Operating Life of Low Temperature 85°C	85°C Operating	1000 Hrs	20 pcs
5	Low temperature storage -40°C	-40°C Storage	1000 Hrs	20 pcs
6	High temperature storage 100°C	100°C Storage	1000 Hrs	20 pcs
7	Steady State Operating Life of High Humidity Heat 60°C/90%	60°C/90% Operating	1000 Hrs	20 pcs
8	Steady State Pulse Operating Life Condition	25°C 10Hz duty=1/10 Operating	200 Cycle	20 pcs
9	Resistance to soldering heat on PCB (JEDEC MSL3)	pre-store@60°C, 60%RH for 52hrs Tslid max.=260 10sec	3 Times	20 pcs
10	Heat Cycle Test (JEDEC MRC)	25°C~65°C~-10°C, 90%RH, 24hr/1cycle	10 Cycle	20 pcs
11	Thermal shock	-40°C/ 20minr~ 5minr~100°C /20min	300 Cycle	20 pcs

■ Judgment Criteria:

Item	Symbol	Test Condition	Judgment Criteria
Forward Voltage	Vf	350 mA	$\Delta V_f < 10\%$
Luminous Flux	Iv	350 mA	$\Delta I_v < 30\%$



Solder Profile:

-The recommended reflow soldering profile is as follows (temperatures indicated are as measured on the surface of the LED resin):

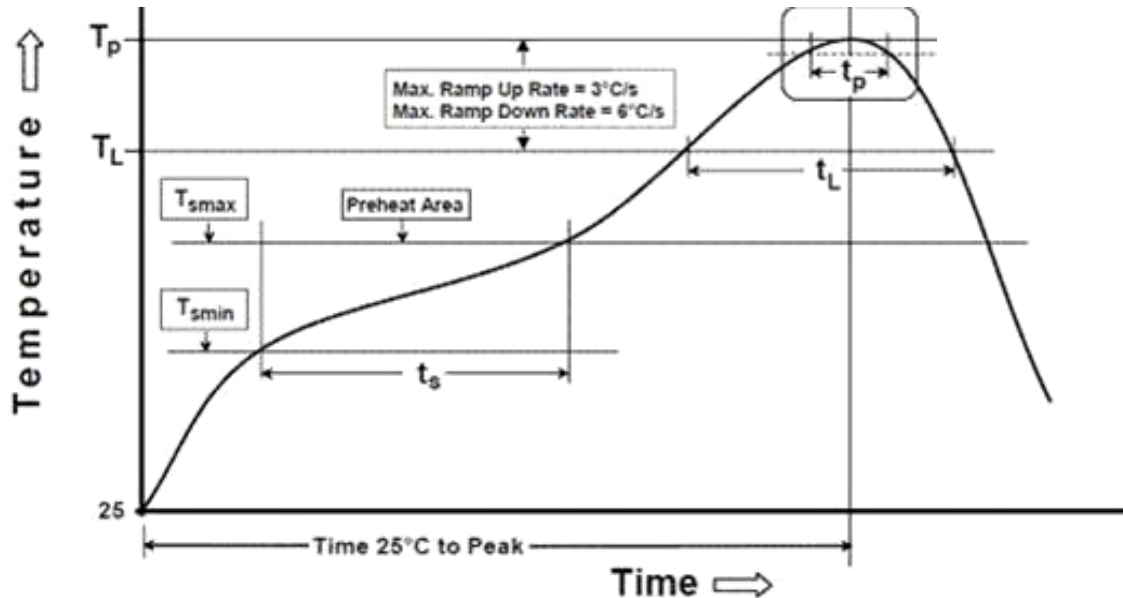

Profile Feature	Sn-Pb Eutectic Assembly	Pb-Free Assembly
Temperature Min(T_{smin})	100°C	150°C
Temperature Max(T_{smax})	150°C	200°C
Time(t_a) from (T_{smin} to T_{smax})	60-120 seconds	60-120 seconds
Ramp-up rate(T_L to T_P)	3°C/second max.	3°C/second max.
Liquidous Temperature(T_L)	183°C	217°C
Time(t_L) maintained above T_L	60-150 seconds	60-150 seconds
Peak package body temperature(T_P)	235°C	260°C
Time within 5°C of Actual Peak temperature (t_p)	20seconds*	30 seconds*
Ramp-down rate(T_P to T_L)	6°C/second max.	6°C/second max.
Time 25°C to peak temperature	6 minutes max.	8 minutes max.
* Tolerance for peak profile temperature (T_P) is defined as a supplier minimum and a user maximum.		



Taping & Packing:

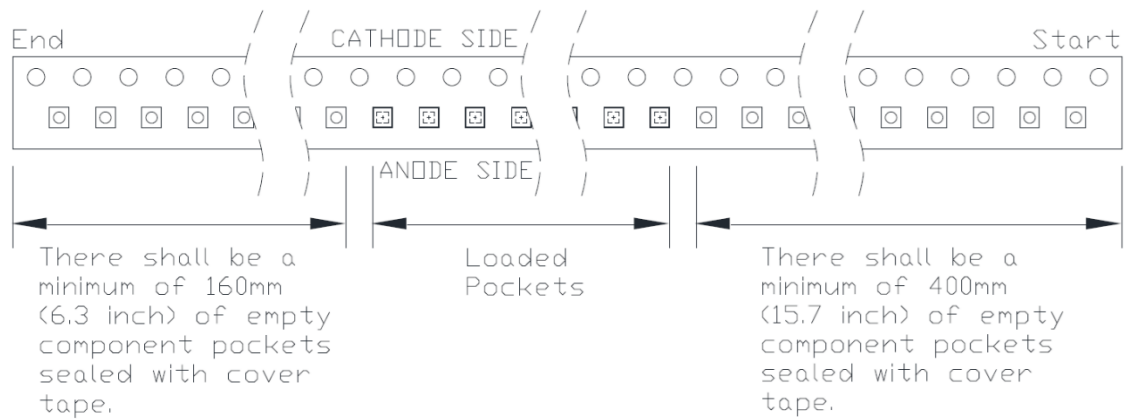
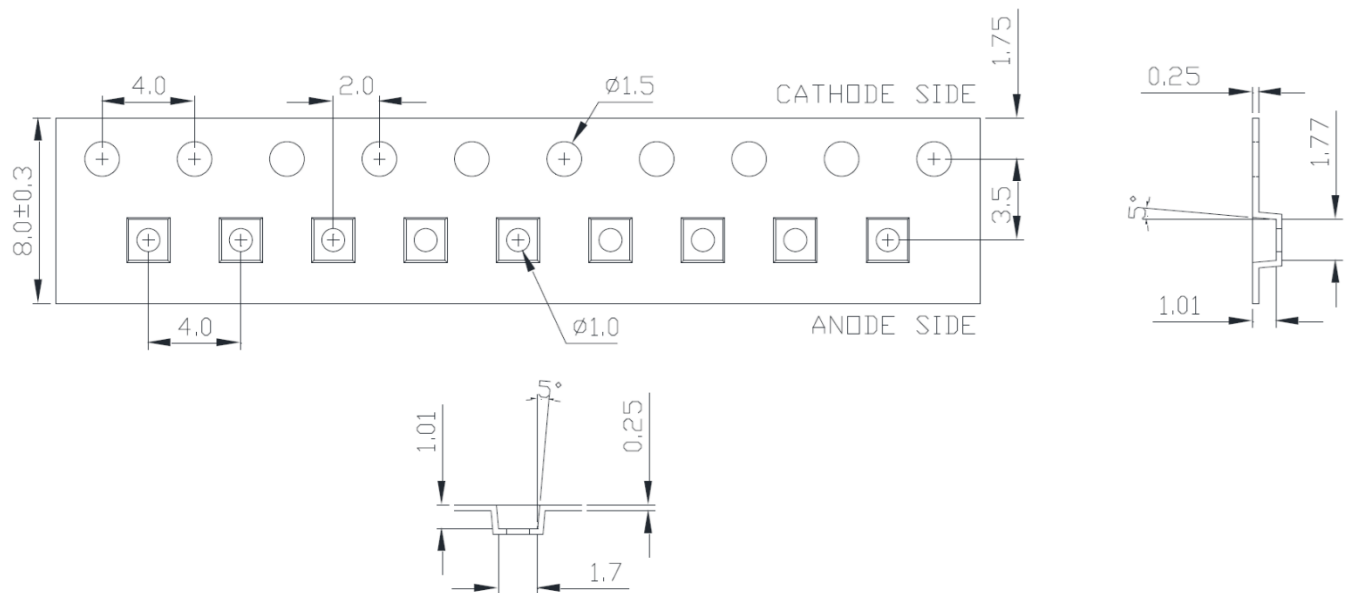

Notes:

1. Drawing not to scale.
2. All dimensions are in millimeters.
3. Unless otherwise indicated, tolerances are ± 0.10 mm.



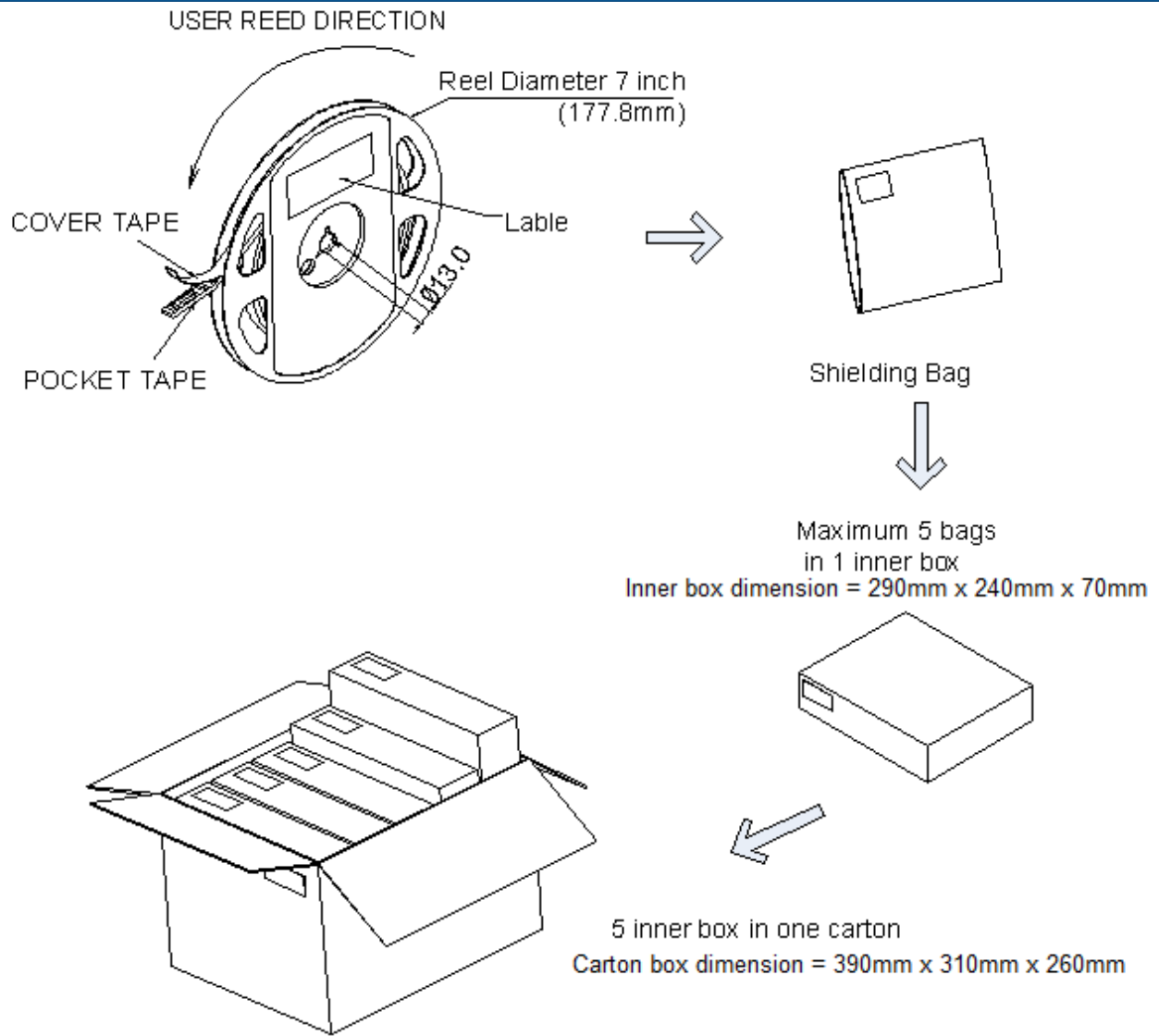

Labeling

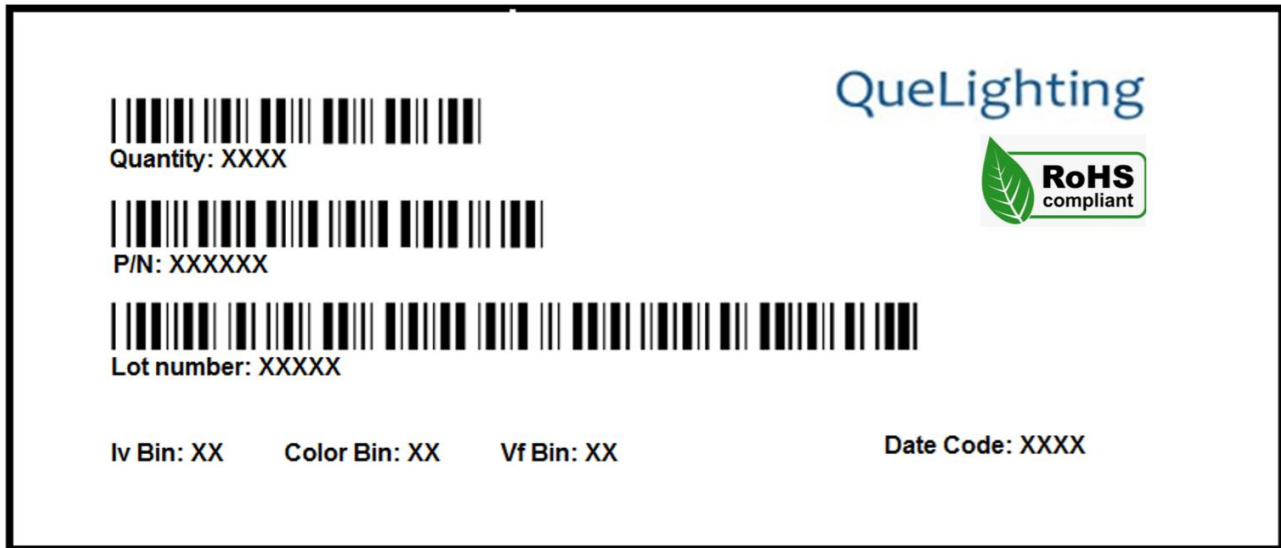

Ordering Information:

Part #	Multiple Quantities	Quantity per Reel
QLSP18UXWEU		1000/2000 pcs



Revision History:

Revision Date:	Changes:	Version #:
06-16-2024	Initial release	1.0

