



Q **QUELIGHTING**
Sustainable Lighting Solution



QLUV07NZGEM
3535 24mW UVC



Product Outline:

The high output type 3535 LEDs, UVC LED series are designed for high current operation and high power output applications. Quelighting UV LED is ideal UV light source for water disinfection.

Features:

- UVC LED
- **Quartz glass lens**
- Max. current = 150mA
- Package Dimension = 3.5mmX3.5mmX1.6mm
- Ceramic substrate
- High Radiant Power output 24mW@100mA
- View angle = 120 degree
- RoHS compliant
- Environmental friendly
- Custom Bin available upon special request

Application:

- Water disinfection
- Air purifiers
- Disinfection
- Phototherapy
- Bio-Analysis/Detection Features

Compliance and Certification:



Mechanical Property:

Top View

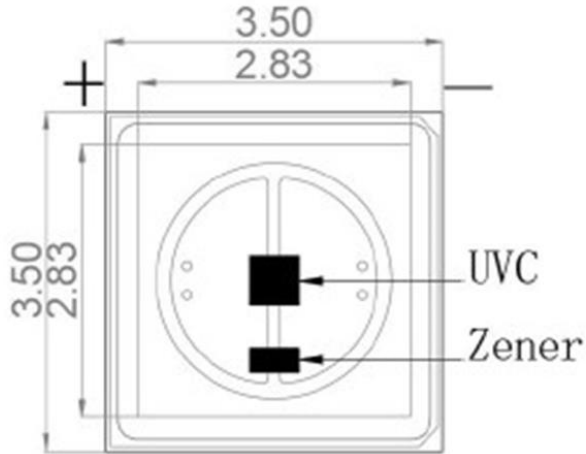

Bottom view

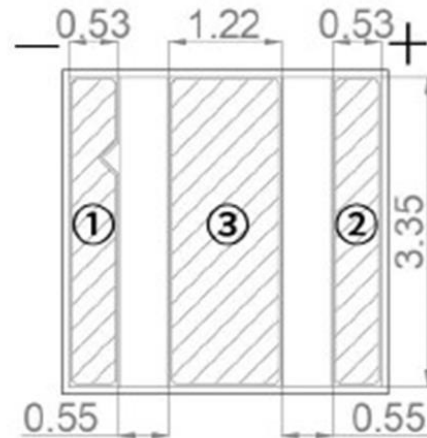

Side View

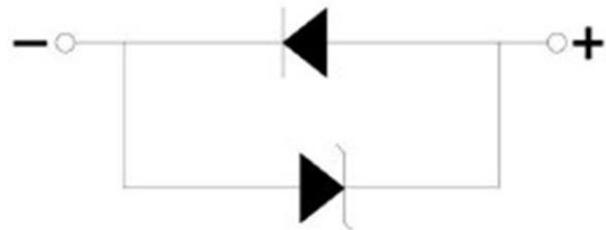

- ① : Cathode
- ② : Anode
- ③ : Thermal

Note:

1. All dimension in millimeters
2. tolerance is $\pm 0.2\text{mm}$



Recommended Solder footprint:

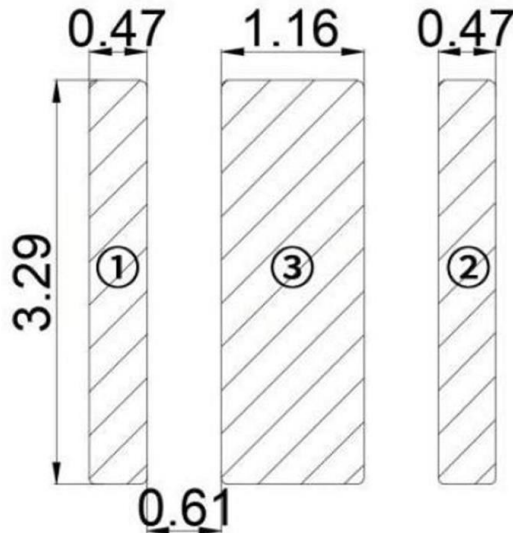

Note:

1. All dimension in millimeters
2. The drawing without tolerances is for reference only
3. Suggest stencil T=0.12 mm

Electrical / Optical Characteristic

(T=25 °C)

Product	View angle	I _F (mA)	V _F (V)		Wavelength (nm)	Radiant Power(mW)	
			Typ.	max		min	typ.
QLUV07NZGEM	120	100	6.0	7	270-280	20	24

- (1) The Forward Voltage tolerance is $\pm 0.1V$
- (2) The Peak wavelength tolerance is ± 2
- (3) The Radiant power is $\pm 7\%$

Absolute Maximum Rating

(T=25 °C)

Part #	P _d (mW)	I _F (mA)	I _{FP} (mA)*	V _R (V)	T _{OP} (°C)	T _{ST} (°C)	T _J (°C)**	T _{SOL} (°C)**	R _{th(J-S)} (C/W)***
QLUV07NZGEM	1	150	150	-5	-30 – 60	-20 - 100	85	240	20

*Duty 1/10 @ 10Khz

** Junction Temperature

*** IR Reflow for no more than 10 sec @ 260 °C

**** Thermal resistance is calculated from junction to solder



Peak Wavelength Binning

Wavelength Rank @ 100mA			
Code name	Low	High	Units
U270T	270	280	nm

Radiant Power

Radiant Power Rank @ 100mA			
Code name	Low	High	Units
B7	20	22	mW
B8	22	24	
B9	24	26	
BA	26	28	

Forward Voltage (V_F) Bin:

VF Rank @ 100mA			
Code name	Min.	Max.	Units
A	5.0	5.5	V
B	5.5	6.0	
C	6.0	6.5	
D	6.5	7.0	



Characteristic Curves

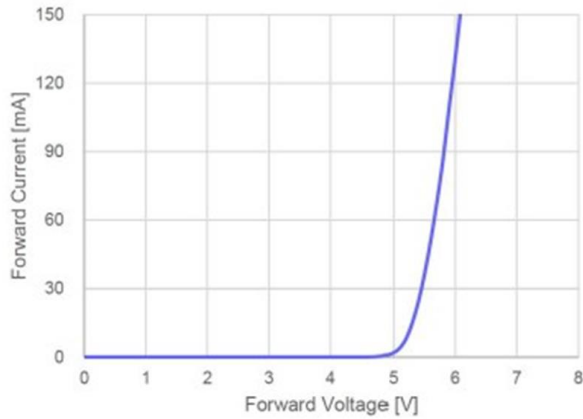

Forward Voltage vs. Forward Current

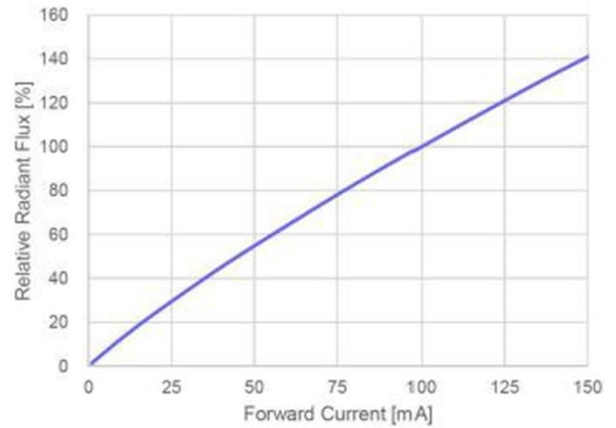

Forward current vs. Relative luminous intensity

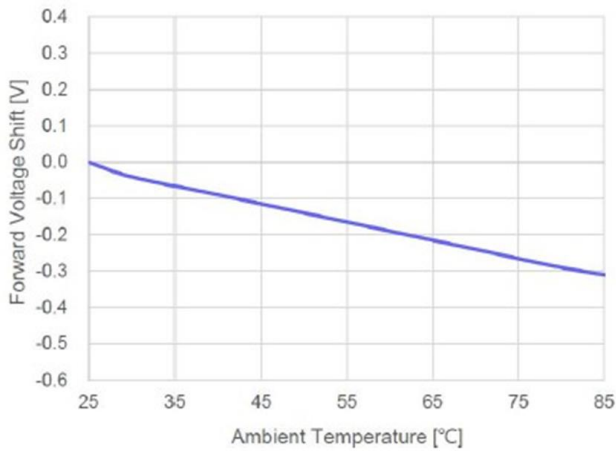

Forward Voltage Shift vs. Ambient Temperature

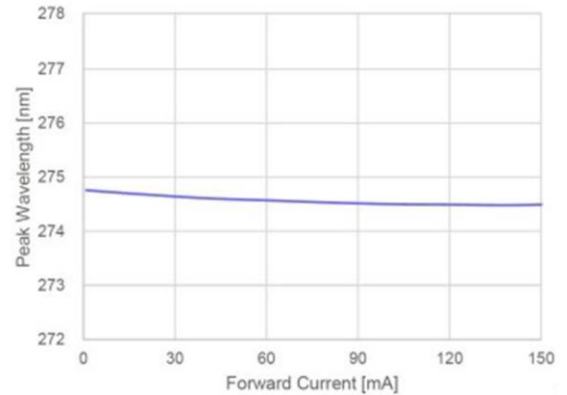

Forward Current vs. Peak Wavelength

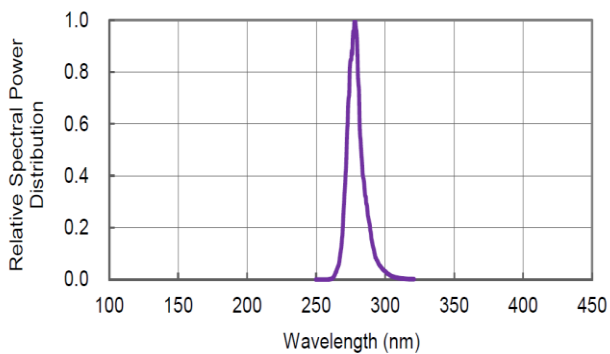

Spectrum Distribution

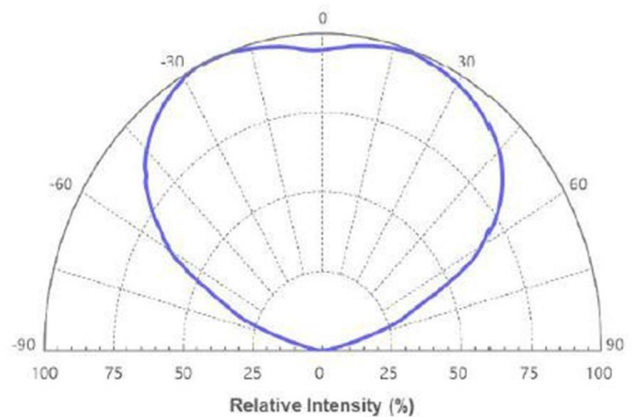

Typical Representative Spatial Radiation Pattern



■ **Reliability test:**

No	Item	Condition	Time/Cycle	Sample size
1	Steady State Operating Life of Room Temperature	25°C Operating	500 Hrs	10 pcs
2	Steady State Operating Life of Low Temperature -40°C	-40°C Operating	500 Hrs	10 pcs
3	Steady State Operating Life of Low Temperature 60°C	60°C Operating	500 Hrs	10 pcs
4	Steady State Operating Life of Low Temperature 85°C	65°C Operating	500 Hrs	10 pcs
5	Low temperature storage -40°C	-40°C Storage	500 Hrs	10 pcs
6	High temperature storage 100°C	100°C Storage	500 Hrs	10 pcs
7	Steady State Operating Life of High Humidity Heat 60°C/90%	60°C/90% Operating	500 Hrs	10 pcs
8	Steady State Pulse Operating Life Condition	25°C 10Hz duty=1/10 Operating	100 Cycle	10 pcs
9	Resistance to soldering heat on PCB (JEDEC MSL3)	pre-store@60°C, 60%RH for 52hrs Tslid max.=260 10sec	3 Times	10 pcs
10	Heat Cycle Test (JEDEC MRC)	25°C~65°C~-10°C, 90%RH, 24hr/1cycle	10 Cycle	10 pcs
11	Thermal shock	-40°C/ 20minr~ 5minr~100°C/20min	100 Cycle	10 pcs

■ **Judgment Criteria:**

Item	Symbol	Test Condition	Judgment Criteria
Forward Voltage	Vf	150 mA	$\Delta Vf < 10\%$
Luminous Flux	Iv	150 mA	$\Delta Iv < 30\%$



Solder Profile:

-The recommended reflow soldering profile is as follows (temperatures indicated are as measured on the surface of the LED resin):

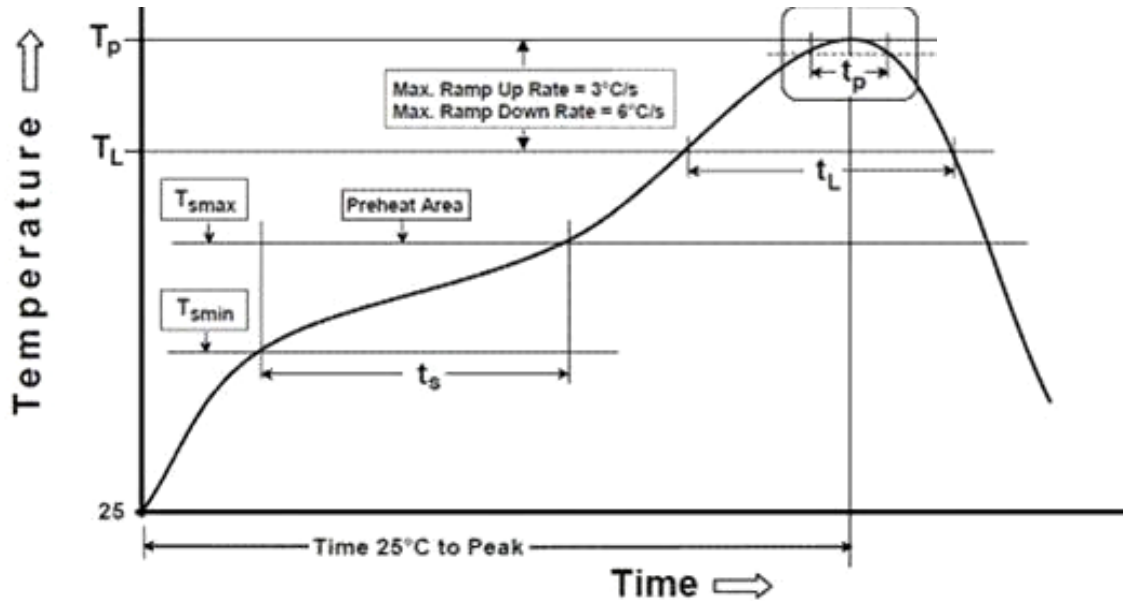

Profile Feature	Sn-Pb Eutectic Assembly	Pb-Free Assembly
Temperature Min(T_{smin})	100°C	150°C
Temperature Max(T_{smax})	150°C	200°C
Time(t_a) from (T_{smin} to T_{smax})	60-120 seconds	60-120 seconds
Ramp-up rate(T_L to T_P)	3°C/second max.	3°C/second max.
Liquidous Temperature(T_L)	183°C	217°C
Time(t_L) maintained above T_L	60-150 seconds	60-150 seconds
Peak package body temperature(T_P)	235°C	260°C
Time within 5°C of Actual Peak temperature (t_p)	20seconds*	30 seconds*
Ramp-down rate(T_P to T_L)	6°C/second max.	6°C/second max.
Time 25°C to peak temperature	6 minutes max.	8 minutes max.
* Tolerance for peak profile temperature (T_P) is defined as a supplier minimum and a user maximum.		



Taping & Packing:

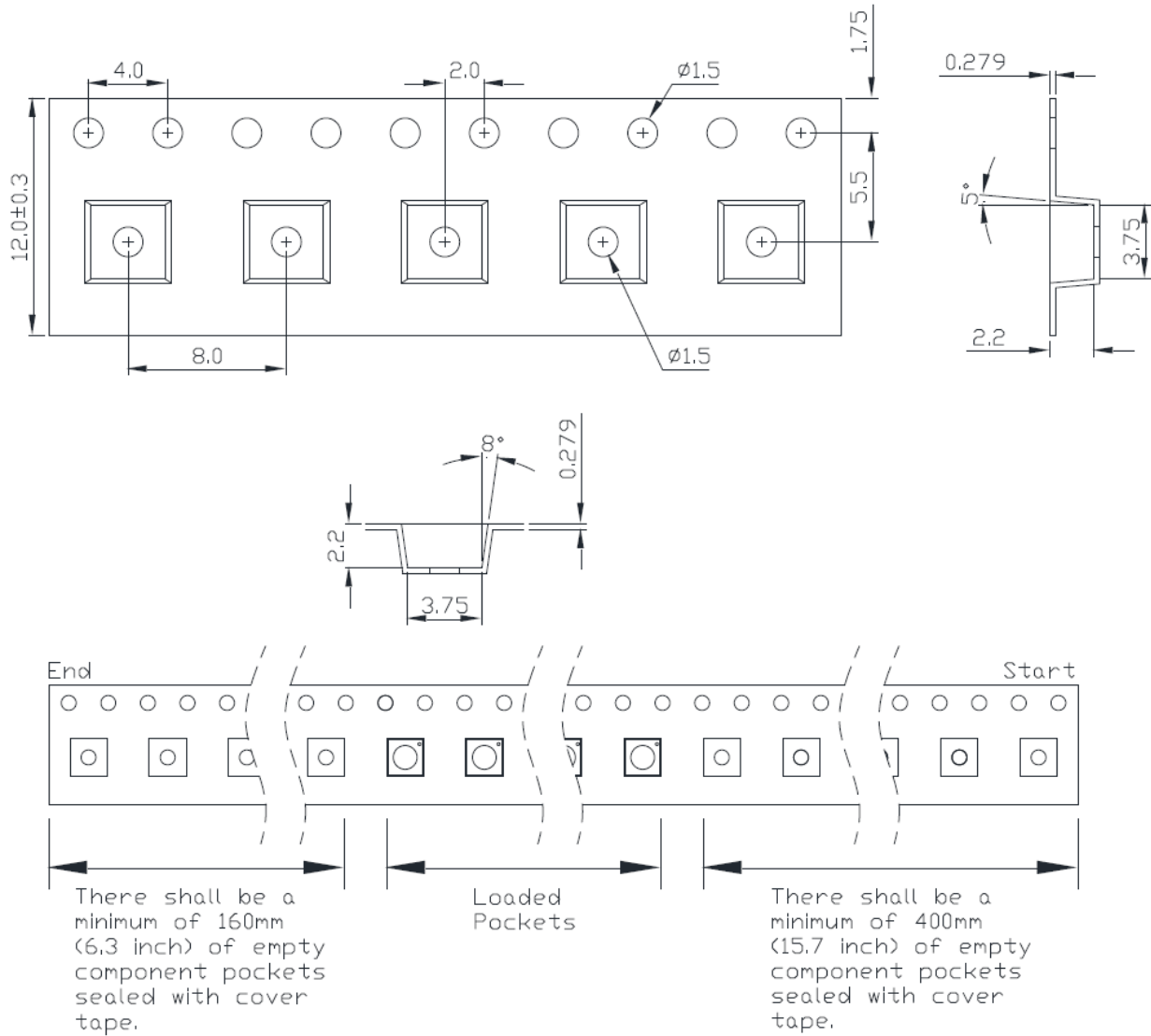

Notes:

1. Drawing not to scale.
2. All dimensions are in millimeters.
3. Unless otherwise indicated, tolerances are ± 0.10 mm.



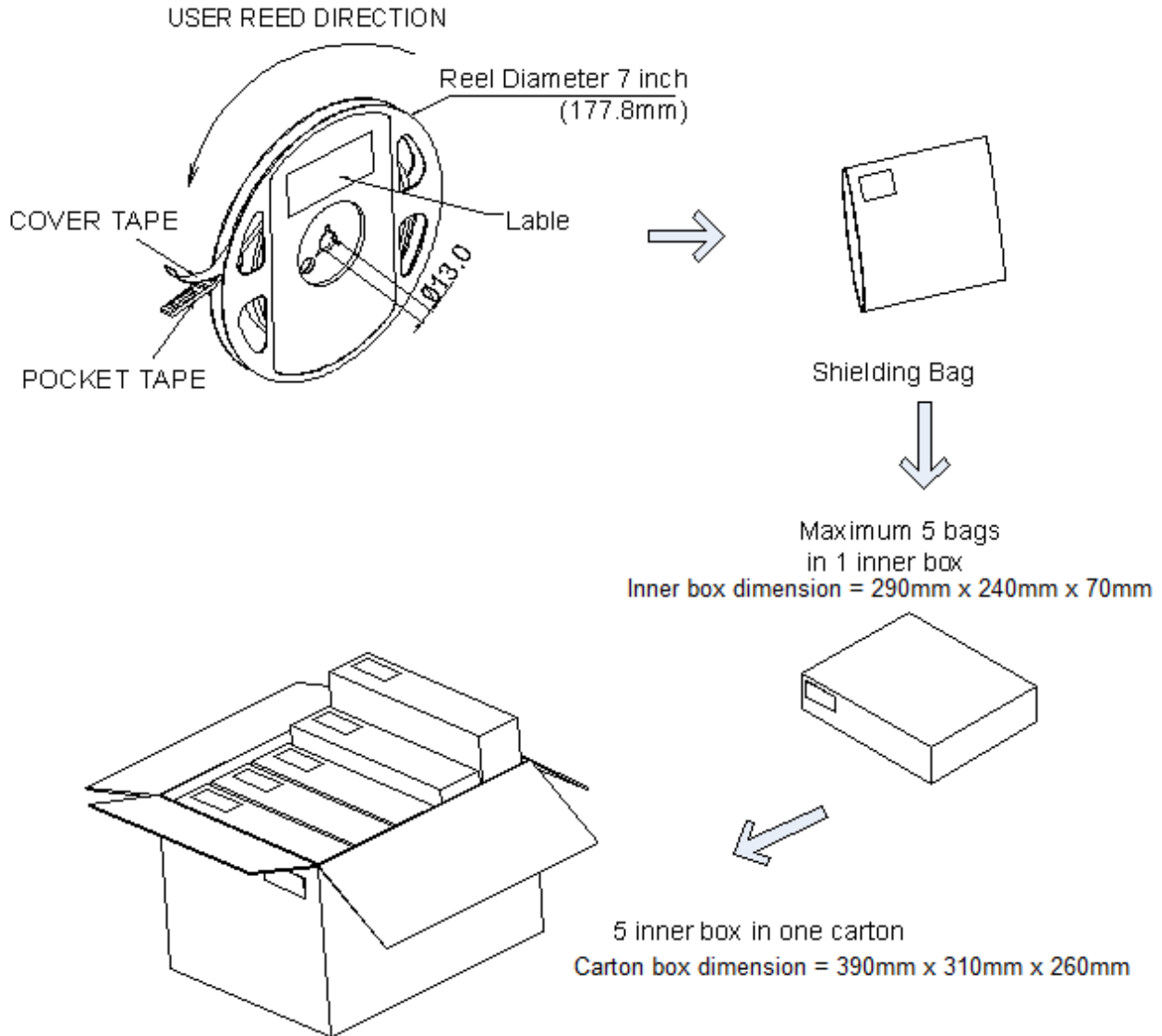

Handling Precautions

- LEDs are ESD (electrostatic discharge) sensitive; static electricity and surge voltages seriously damage UV LEDs and can result in product failure
- Use proper ESD protection, including grounded wrist straps, ESD footwear and clothes
- Ensure that tools, jigs and machines being used are properly grounded
- LED mounting equipment should include protection against voltage surge
-
- The UVC LED is not protected by a lens and requires careful handling



- Do not handle the LED with bare hands as it may contaminate the LED surface and affect the optical characteristics.
- Avoid touching the LED die
- Do not use adhesives that outgas organic vapor
- Dropping the product may cause damage
- If handling the product with tweezers, use only the side of the package and be careful not to apply excessive force
- Proper thermal management is required to prevent warpage and damage to the modules and its components.
- Do not apply mechanical force or excess vibration during handling or normal operation

Storage Precautions

Please do not open the moisture proof package (with silica desiccant).more than one week. This may cause the leads of LED discoloration.

We recommend storing LEDs in a dry box once moisture proof bag is opened.

The recommended storage conditions are temperature 5 to 30°C and humidity less than 40% RH. It is also recommended to restore the LEDs into the moisture proof bag and reseal it.

Notes for handling Quartz lens LEDs

- Avoid touching the quartz lens especially by sharp tools such as Tweezers.
- Avoid leaving fingerprints on the quartz lens.
- Please store the LEDs away from dusty areas or seal the product against dust.
- Under SMT production, please avoid the mechanical pressure on the quartz lens.
- Please do not mold over the quartz lens with another resin. (epoxy, urethane, etc)

Eye Safety Guidelines During operation

The LED emits high intensity ultraviolet (UV) light, which is harmful to skin and eyes. UV light is hazardous to skin and may cause cancer.

- 1) Avoid looking directly at the UV light: Wear protective glasses/goggle with ANSI Z87 rated.
- 2) Wear facial shield / Lab Coat with long sleeve / Gloves to cover skin may exposed to UVC LEDs.
- 3) Attach warning labels on products/systems that is composed with UV LEDs.

Warning label:

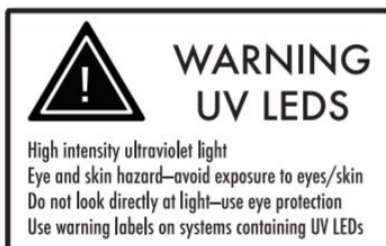

Labeling

 Quantity: XXXX



 P/N: XXXXXX



 Lot number: XXXXX

Iv Bin: XX

Color Bin: XX

Vf Bin: XX

Date Code: XXXX

Ordering Information:

Part #	Multiple Quantities	Quantity per Reel
QLUV07NZGEM		500,1000



Revision History:

Revision Date:	Changes:	Version #:
10-10-2024	Initial release	1.0

